



**POWERTECH (USA) INC.**

**Dewey-Burdock Project  
Report to Accompany Inyan Kara Water Right  
Permit Application  
Custer and Fall River Counties,  
South Dakota**

Prepared for:

**South Dakota Department of Environment and Natural Resources**  
Water Rights Program  
523 E. Capitol Avenue  
Pierre, SD 57501

Prepared by:

**Powertech (USA), Inc.**  
P.O. Box 812  
Edgemont, SD 57735

June 2012

## TABLE OF CONTENTS

EXECUTIVE SUMMARY .....	v
1.0 INTRODUCTION.....	1
1.1 Applicant Information.....	7
2.0 REQUESTED WATER APPROPRIATION .....	8
2.1 Purpose and Need for Water Appropriation .....	8
2.2 Project Overview.....	9
2.3 Appropriation Volume .....	11
2.4 Groundwater Withdrawal System.....	12
2.4.1 Approach to Well Field Development.....	12
2.4.2 Well Field Development Schedule.....	19
2.4.3 Well Construction and Integrity Testing .....	22
2.4.3.1 Well Construction Materials.....	22
2.4.3.2 Well Construction Methods.....	23
2.4.3.3 Well Development.....	25
2.4.3.4 Well Integrity Testing.....	25
2.5 Diversion Area .....	26
3.0 HYDROGEOLOGIC SETTING.....	28
3.1 Geology.....	28
3.1.1 Regional Geology .....	28
3.1.1.1 Regional Structure .....	28
3.1.1.2 Regional Stratigraphy.....	28
3.1.2 Site Geology .....	30
3.1.2.1 Site Structure .....	33
3.1.2.2 Site Stratigraphy .....	33
3.2 Hydrogeology.....	38
3.2.1 Regional Hydrogeology.....	38
3.2.1.1 Inyan Kara Aquifer.....	40
3.2.2 Site Hydrogeology .....	40
3.2.2.1 Site Hydrostratigraphic Units.....	41
3.2.3 Groundwater Occurrence and Flow .....	41
3.2.3.1 Groundwater Flow Systems.....	44
3.2.3.1.1 Groundwater Recharge and Discharge.....	45
3.2.3.1.2 Hydraulic Isolation of Aquifers .....	45

**TABLE OF CONTENTS (Continued)**

3.2.3.1.3	Groundwater Use .....	47
4.0	POTENTIAL IMPACTS.....	48
4.1	Water Availability.....	48
4.2	Potential Impacts to Existing Water Rights and Domestic Wells.....	48
4.2.1	Existing Groundwater Rights .....	48
4.2.2	Well Inventory .....	51
4.2.3	Potential Drawdown Impacts.....	52
4.2.4	Potential to Unlawfully Impair Existing Water Rights or Domestic Wells.....	55
5.0	MONITORING AND MITIGATION PLAN .....	57
6.0	PERMIT ADMINISTRATION AND REPORTING.....	58
7.0	REFERENCES .....	60

**LIST OF TABLES**

Table 1-1:	Surface and Mineral Ownership, Dewey-Burdock Project Area.....	4
Table 2-1:	Maximum Anticipated Inyan Kara Water Usage and Requested Appropriation Amount.....	12
Table 3-1:	Summary of Hydraulic Properties of the Inyan Kara Aquifer.....	41
Table 3-2:	Estimated Groundwater Use in Custer and Fall River Counties, South Dakota.....	47
Table 4-1:	Groundwater Rights within 2 km of the Dewey-Burdock Project Area.....	50
Table 6-1:	Inyan Kara Water Rights Reporting Schedule.....	58

**LIST OF FIGURES**

Figure 1-1:	Dewey-Burdock Project Location Map .....	2
Figure 1-2:	Inyan Kara Diversion Area .....	3
Figure 2-1:	Potential Well Field Areas .....	14
Figure 2-2:	Typical Injection Wellhead.....	15
Figure 2-3:	Typical Production Wellhead .....	16
Figure 2-4:	Proposed Facilities and Potential Initial Well Field Areas, Land Application Option.....	17
Figure 2-5:	Proposed Facilities and Potential Initial Well Field Areas, Deep Disposal Well Option.....	18
Figure 2-6:	Projected Construction, Operation, Restoration and Decommissioning Schedule.....	20

**TABLE OF CONTENTS (Continued)**

Figure 2-7:	Anticipated Production Well Construction Schedule - Dewey Portion of the Project Area.....	21
Figure 2-8:	Anticipated Production Well Construction Schedule - Burdock Portion of Project Area .....	21
Figure 2-9:	Typical Well Construction.....	24
Figure 3-1:	Geologic Map of the Black Hills .....	29
Figure 3-2:	Stratigraphic Column of the Black Hills Area.....	31
Figure 3-3:	Site Surface Geology .....	32
Figure 3-4:	Type Log.....	34
Figure 3-5:	Diagram Showing a Simplified View of the Hydrogeologic Setting of the Black Hills Area.....	39
Figure 3-6:	Potentiometric Contour Map, Fall River Formation.....	42
Figure 3-7:	Potentiometric Contour Map, Chilson Member.....	43
Figure 3-8:	Recharge Areas for the Fall River and Lakota Formations .....	46
Figure 4-1:	Groundwater Rights within 2 km of the Dewey-Burdock Project Area.....	49
Figure 4-2:	Maximum Fall River Drawdown Simulation .....	53
Figure 4-3:	Maximum Chilson Drawdown Simulation.....	54

**LIST OF PLATES**

Plate 2-1	Typical Well Field Layout
Plate 2-2	Typical Header House
Plate 3-1	Structure Map of the Top of Chilson Member
Plate 3-2	Structure Map of the Top of Fuson Shale
Plate 3-3	Structure Map of the Top of Fall River Formation
Plate 3-4	Isopach of the Chilson Member
Plate 3-5	Isopach of the Fuson Shale
Plate 3-6	Isopach of the Fall River Formation
Plate 3-7	Geologic Cross Section
Plate 4-1	Wells within 2 km of Project Boundary

## **TABLE OF CONTENTS (Continued)**

### **LIST OF APPENDICES**

- Appendix A Water Levels in Inyan Kara Wells
- Appendix B Well Inventory Summary Tables
- Appendix C Well Inventory
- Appendix D Numerical Groundwater Model Report

## EXECUTIVE SUMMARY

This report accompanies an Application for Permit to Appropriate Water from the Inyan Kara aquifer within the State of South Dakota, Form 2, submitted by Powertech (USA) to DENR. The permit to appropriate water from the Inyan Kara aquifer is one of several permits required for Powertech (USA) to recover uranium in the Dewey-Burdock Project, which is located about 13 miles north-northwest of Edgemont, SD.

Powertech (USA) proposes to recover uranium by a method known as *in situ* recovery, or ISR, in which groundwater from the formation containing uranium (the Inyan Kara Group) is pumped to the surface from a field of wells, fortified with oxygen and carbon dioxide, and recirculated through the formation. The oxidized groundwater changes the uranium to a soluble form and is pumped to the surface, where the uranium is removed from solution and processed into yellowcake. The yellowcake will be shipped off site for further processing into fuel for electric energy production. After the uranium is removed, the groundwater is refortified with oxygen and carbon dioxide and recirculated through the well fields; the process is repeated until the economic reserves of uranium are fully removed from that particular well field. Then the process moves to another well field, and the depleted well field is restored by continuing to circulate clean water through the wells until the water is similar to the water that existed in the formation prior to the ISR operations.

Because most of the water removed during the ISR process is recirculated through the well field, the net consumptive use of water is a small portion of the gross withdrawal rate. A small amount of water is “bled off” during the process in order to maintain flow gradients toward the center of the well field and help to control the flow of the recovery solutions. The “bleed stream” is treated to remove uranium and uranium decay products and disposed in deep disposal wells or by land application. The disposal method has not yet been finalized; Powertech (USA)’s preferred disposal method will be deep disposal wells. A separate permitting action with EPA is ongoing, and once the necessary permits are received the testing can be undertaken to determine the feasibility of constructing deep disposal wells in this area. If deep disposal wells are not feasible in this area, the land application method will be used. Another permitting action is underway with DENR to authorize the land application. It is possible that a combination of methods will be necessary.

The water withdrawal rate will vary depending upon geological and market conditions. The system will be designed and operated to produce a certain number of pounds of yellowcake per year, and the water throughput will vary depending on formation permeability, ore grade and other factors in order to achieve the production goals.



Powertech (USA) estimates that a maximum net withdrawal rate of 170 gpm will be required to achieve production goals. This equates to about 0.38 cfs or, if sustained for an entire year, 274.2 ac-ft. This net withdrawal represents about 2% of the gross withdrawal, with the other 98% being recirculated through the well field. Following guidance from DENR personnel, the water application is for the gross withdrawal rate of up to 8,500 gpm, which equates to 18.938 cfs or 13,710.6 ac-ft per year. This is the maximum withdrawal rate and it will not be exceeded.

SDCL 46-2A-9 states that, “A permit to appropriate water may be issued only if there is reasonable probability that there is unappropriated water available for the applicant's proposed use, that the proposed diversion can be developed without unlawful impairment of existing rights and that the proposed use is a beneficial use and in the public interest.” Each of these conditions is addressed in this report. A groundwater model was used to demonstrate that there is unappropriated water for Powertech (USA)’s proposed use and that drawdowns will be minimal and will not impair any existing rights. The model results show that the maximum anticipated drawdown in the Inyan Kara aquifer will be 10 to 12 feet at the edge of the project area. SDCL 46-1-6(3) defines beneficial use as “any use of water within or outside the state, that is reasonable and useful and beneficial to the appropriator, and at the same time is consistent with the interests of the public of this state in the best utilization of water supplies.” SDCL 46-1-8 defines beneficial use as “the basis, measure and limit of the right to the use of the waters [of the state].” The amount of water requested in this appropriation has been carefully determined by engineering analysis as the amount necessary to recover the uranium while protecting water resources outside the area. Additional support for uranium ISR to be considered a beneficial use is found in SDCL 45-6B, which states, “Every effort should be used to promote and encourage the development of mining as an industry, but to prevent the waste and spoilage of the land and the improper disposal of tailings which would deny its use and productivity” and SDCL 45-6B-3(11), which includes *in situ* mining in the definition of “mining operation.”

The Dewey-Burdock Project will provide public benefits in the form of employment opportunities (250 jobs during construction and 150 new jobs during operation) and state and local tax revenues.

## 1.0 INTRODUCTION

Powertech (USA), Inc. [Powertech (USA)] is submitting an application for a water right permit within the State of South Dakota for the Inyan Kara aquifer. The permit application and this accompanying report have been prepared in accordance with the requirements of SDCL Title 46. Powertech (USA) is a U.S.-based corporation incorporated in South Dakota and a wholly owned subsidiary of Powertech Uranium Corporation, a Canadian Company. In addition to the Dewey-Burdock Project, Powertech (USA) has one exploration permit in Colorado (Centennial Project) and two exploration permits in Wyoming (Dewey Terrace and Aladdin projects).

The Dewey-Burdock Project is a proposed uranium *in situ* recovery (ISR) project located approximately 13 miles north-northwest of Edgemont, South Dakota, in an area encompassing portions of Fall River and Custer counties. The Dewey-Burdock Project area (project area) encompasses approximately 10,580 acres of mostly private land on both sides of S. Dewey Road (County Road 6463) and includes portions of Sections 1-5, 10-12, and 14-15, Township 7 South, Range 1 East and Sections 20-21 and 27-35, Township 6 South, Range 1 East, Black Hills Meridian. Approximately 240 acres are under control of the Bureau of Land Management (BLM) in portions of Sections 3 and 10-12. The Dewey-Burdock Project location is shown on Figure 1-1. Figure 1-2 depicts the proposed groundwater diversion area. Table 1-1 shows the surface and mineral ownership within the project area. Through various mineral claims, leases, and other agreements Powertech (USA) has acquired the legal right to conduct ISR operations within the project area.

The permit application proposes a permitted gross diversion (pumping) rate of up to 13,710.6 ac-ft/yr (8,500 gpm). The vast majority of the water withdrawn under this appropriation will be reinjected as part of the ISR process, such that the net annual average withdrawal rate will be no more than 274.2 ac-ft/yr (170 gpm). The gross and net pumping rates are shown on the application form. This report demonstrates that the Inyan Kara aquifer has adequate capacity to provide the requested appropriation while assuring that users of water from the aquifer outside the project area will not be adversely affected by this appropriation. Because most of the water withdrawn under this appropriation is continuously reinjected, only the net withdrawal is considered when evaluating potential impacts to other water users.

This application is organized into seven sections including this introduction. Section 2 describes the purpose and need for the water appropriation and gives a project overview including appropriation volume and well design. Section 3 summarizes the hydrogeologic setting. Section 4 provides a discussion of drawdown estimates and potential impacts to users. Section 5



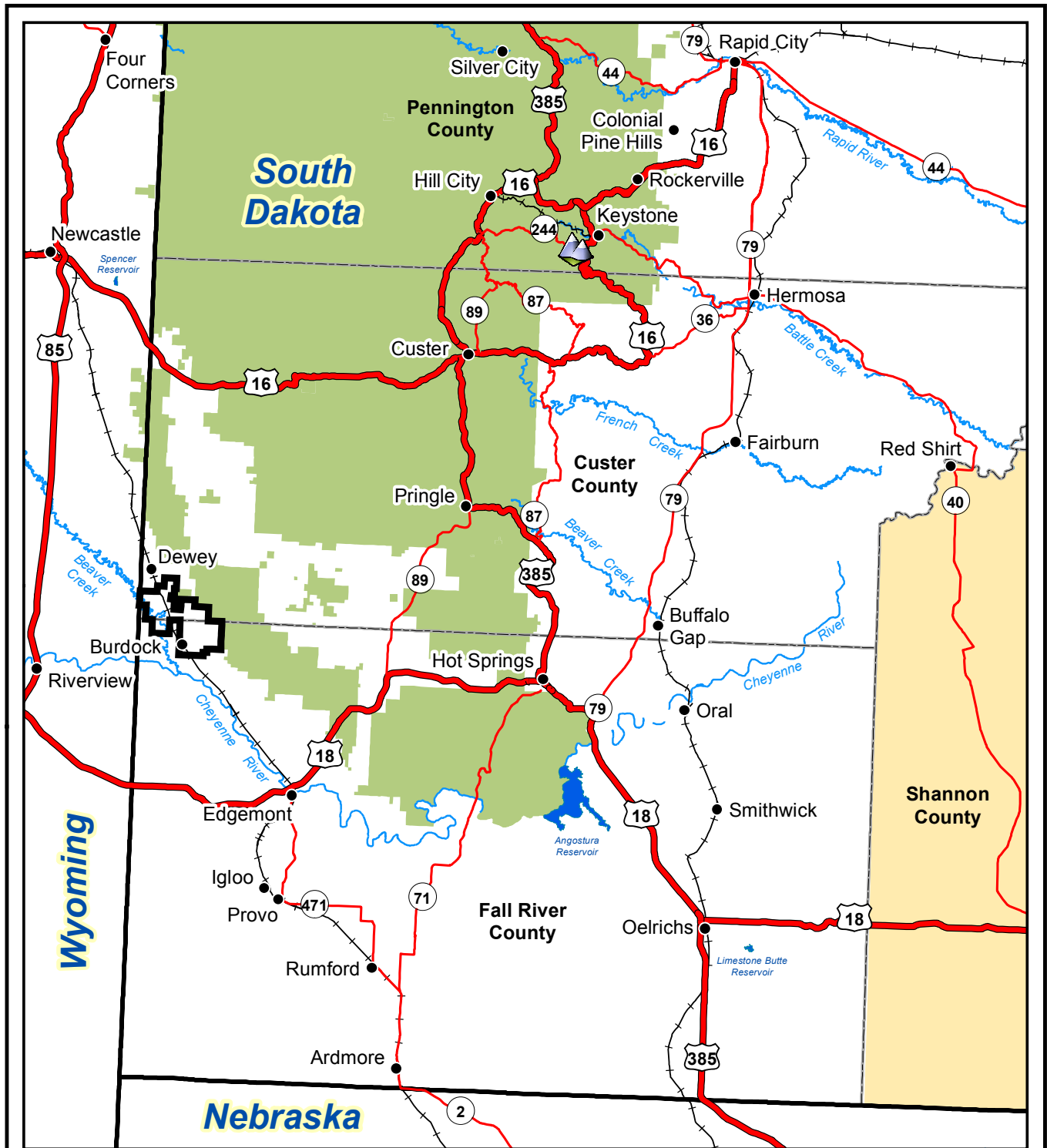

**Legend**

- Towns
- ▬ Project Boundary
- ~ Rivers and Streams
- Pine Ridge Reservation
- Black Hills National Forest
- ▲ Mt. Rushmore National Memorial

- Transportation**
- ▬ US Highway
  - ▬ State Highway
  - +— Railroad



**Figure 1-1**  
Dewey-Burdock Project  
Location Map

**Dewey-Burdock Project**

DRAWN BY	Mays, Hetrick
DATE	13-Mar-2012
FILENAME	DBProjLocMap.mxd



**POWERTECH (USA) INC.**

This document originally issued and sealed by John M. Mays, Vice President - Engineering, South Dakota Registered Professional Engineer Reg. No. 11295, on June 8, 2012. This media should not be considered a certified document

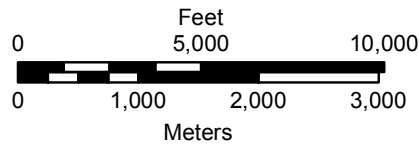
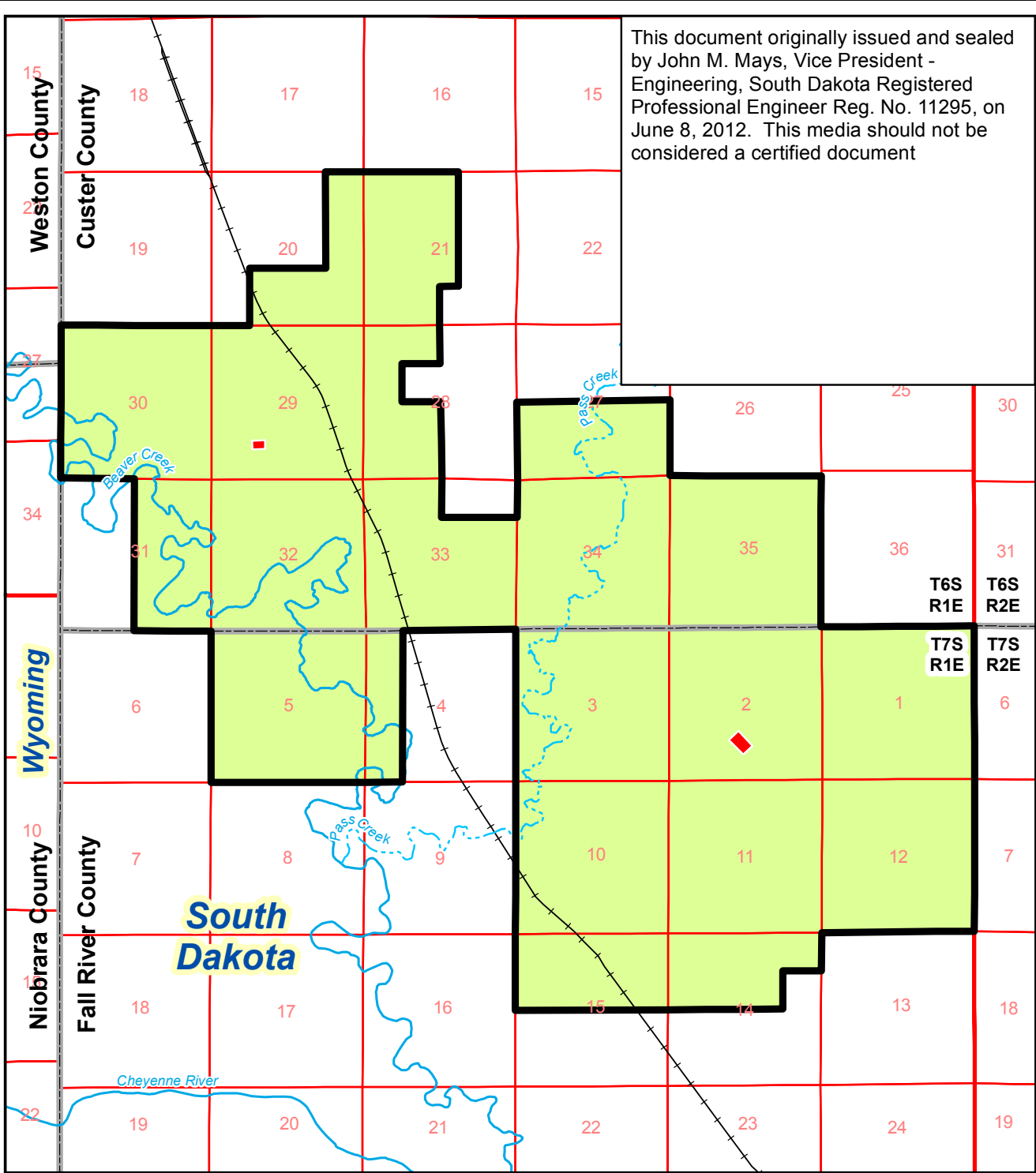

**Legend**

- Project Boundary
- BNSF Railroad
- Ephemeral Streams
- Perennial Streams
- Processing Plants
- Inyan Kara Diversion Area

**Note:**  
This drawing is provided to fulfill the requirements of ARSD 74:02:01:07.



**Figure 1-2**

Inyan Kara Diversion Area

Dewey-Burdock Project

DRAWN BY	Mays, Hetrick
DATE	5-Jun-2012
FILENAME	H2ORightDiv.mxd



**Table 1-1: Surface and Mineral Ownership, Dewey-Burdock Project Area**

	Legal Description	Area (acres)	Surface Owner(s)	Mineral Owner(s)
<b>Township 6S, Range 1E, Custer County, SD</b>				
<b>Black Hills Meridian</b>				
Section 20	E $\frac{1}{2}$ NE $\frac{1}{4}$ ; E $\frac{1}{2}$ SE $\frac{1}{4}$ ; SW $\frac{1}{4}$ SE $\frac{1}{4}$ ; S $\frac{1}{2}$ NW $\frac{1}{4}$ SE $\frac{1}{4}$ ; SE $\frac{1}{4}$ SW $\frac{1}{4}$ ; S $\frac{1}{2}$ NE $\frac{1}{4}$ SW $\frac{1}{4}$	280	GCC Dacotah, Inc.	BLM Minerals
Section 21	W $\frac{1}{2}$ ; W $\frac{1}{2}$ SW $\frac{1}{4}$ NE $\frac{1}{4}$ ; W $\frac{1}{2}$ NW $\frac{1}{4}$ SE $\frac{1}{4}$	360	GCC Dacotah, Inc.	BLM Minerals
	W $\frac{1}{2}$ NW $\frac{1}{4}$ NE $\frac{1}{4}$	20	Donald L. Spencer	BLM Minerals
Section 27	W $\frac{1}{2}$ SW $\frac{1}{4}$ ; E $\frac{1}{2}$ SE $\frac{1}{4}$	160	Clayton Sander	BLM Minerals
	E $\frac{1}{2}$ SW $\frac{1}{4}$ ; W $\frac{1}{2}$ SE $\frac{1}{4}$	160	Clayton Sander	Clayton Sander
Section 28	N $\frac{1}{2}$ NW $\frac{1}{4}$ ; SW $\frac{1}{4}$ NW $\frac{1}{4}$	120	GCC Dacotah, Inc.	BLM Minerals
	SW $\frac{1}{4}$	160	Putnam & Putnam, LLP	BLM Minerals
Section 29	SW $\frac{1}{4}$ NE $\frac{1}{4}$ ; N $\frac{1}{2}$ NW $\frac{1}{4}$ ; W $\frac{1}{2}$ SE $\frac{1}{4}$	200	GCC Dacotah, Inc.	Richard E. Elston; Elston Bros. Realty Co., LLC
	N $\frac{1}{2}$ NE $\frac{1}{4}$ ; SE $\frac{1}{4}$ NE $\frac{1}{4}$ ; S $\frac{1}{2}$ NW $\frac{1}{4}$ ; SW $\frac{1}{4}$ ; E $\frac{1}{2}$ SE $\frac{1}{4}$	440	GCC Dacotah, Inc.	BLM Minerals
Section 30	NE $\frac{1}{4}$ ; W $\frac{1}{2}$	480	GCC Dacotah, Inc.	Francis A. and Phyllis Jozwik Paul and Janet Jozwik Robert and Alice Barnard (Barnard & Lowham, LLC) William and Joyce Barnard (Barnard & Lowham, LLC) Paul Lowham (Barnard & Lowham, LLC)
	SE $\frac{1}{4}$	160	GCC Dacotah, Inc.	Richard E. Elston; Elston Bros. Realty Co., LLC
Section 31	E $\frac{1}{2}$	320	Bakewell-Andis Ranch, LLP	Bakewell-Andis Ranch, LLP
Section 32	NE $\frac{1}{4}$ NE $\frac{1}{4}$ ; N $\frac{1}{2}$ NW $\frac{1}{4}$	120	GCC Dacotah, Inc.	BLM Minerals
	NW $\frac{1}{4}$ NE $\frac{1}{4}$ ; S $\frac{1}{2}$ NE $\frac{1}{4}$ ; S $\frac{1}{2}$ NW $\frac{1}{4}$	200	GCC Dacotah, Inc.	Richard E. Elston; Elston Bros. Realty Co., LLC
	S $\frac{1}{2}$	320	Putnam & Putnam, LLP	Putnam & Putnam, LLP
Section 33	S $\frac{1}{2}$ NE $\frac{1}{4}$ ; SE $\frac{1}{4}$	240	Donald and Pat Spencer	BLM Minerals
	W $\frac{1}{2}$	320	Putnam & Putnam, LLP	BLM Minerals
Section 34	NE $\frac{1}{4}$ NE $\frac{1}{4}$	40	Donald and Pat Spencer	BLM Minerals
	W $\frac{1}{2}$ NE $\frac{1}{4}$ ; SE $\frac{1}{4}$ NE $\frac{1}{4}$ ; W $\frac{1}{2}$ ; SE $\frac{1}{4}$	600	Donald and Pat Spencer	Donald and Pat Spencer
Section 35	NE $\frac{1}{4}$ ; E $\frac{1}{2}$ NW $\frac{1}{4}$ ; NW $\frac{1}{4}$ NW $\frac{1}{4}$ ; NE $\frac{1}{4}$ SW $\frac{1}{4}$ ; N $\frac{1}{2}$ SE $\frac{1}{4}$	400	Donald and Pat Spencer	BLM Minerals
	SW $\frac{1}{4}$ NW $\frac{1}{4}$ ; NW $\frac{1}{4}$ SW $\frac{1}{4}$	80	Donald and Pat Spencer	Donald and Pat Spencer
	S $\frac{1}{2}$ SW $\frac{1}{4}$ ; S $\frac{1}{2}$ SE $\frac{1}{4}$	160	Chris and Amy Daniel	Chris and Amy Daniel

**Table 1-1. Surface and Mineral Ownership, Dewey-Burdock Project Area (Continued)**

	Legal Description	Area (acres)	Surface Owner(s)	Mineral Owner(s)
<b>Township 7S, Range 1E, Fall River County, SD</b>				
<b>Black Hills Meridian</b>				
Section 1	All	640	Daniel Properties, LLC	BLM Minerals
Section 2	All	640	Daniel Properties, LLC	Daniel Properties, LLC
Section 3	N½; SW¼; N½SE¼; SW¼SE¼	600	Donald and Pat Spencer	Donald and Pat Spencer
	SE¼SE¼	40	BLM	BLM Minerals
Section 4	W½W½	160	Putnam & Putnam, LLP	Putnam & Putnam, LLP
Section 5	All	640	Putnam & Putnam, LLP	Putnam & Putnam, LLP
Section 10	NE¼; W½SE¼; E½SW¼; SW¼NW¼SW¼; SW¼SW¼ minus 3.97 ac in NE portion	366.03	Peterson & Son, Inc.	Peterson & Son, Inc. Black Stone Minerals Company, LP Jean Swirczynski Roy Guess
	NW¼NW¼SW¼	10	TerraTecTonics Corporation	TerraTecTonics Corporation
	E½NW¼SW¼ minus lots in southern portion (1.44 ac)	18.56	Donald and Lynda Andersen	Donald and Lynda Andersen
	14 lots in southern portion of E½NW¼SW¼; 3.97 ac in NE portion of SW¼SW¼	5.1	Kathleen Klausen	Kathleen Klausen
	4 lots in southern portion of E½NW¼SW¼	0.31	Clifford James Lovell and Patricia C. Johnson	Clifford James Lovell and Patricia C. Johnson
	N½NW¼	80	Donald and Pat Spencer	Steven and Elizabeth Laesch Roger C. and Jeanette R. Laesch Christopher and Kelly Ann Viel Rev. Norman and Joyce Laesch Carol A. Laesch Barbara Jacqueline S. Laesch Ellison Frederick and Marilyn Laesch Helen L. and Carl Leroy Kellberg Rev. Richard and Irene L. Mueller William J. Laesch Allen G. and Barbara B. Wilson
	S½NW¼	80	Donald and Pat Spencer	Donald and Pat Spencer
NE¼SE¼	40	BLM	BLM Minerals	

**Table 1-1. Surface and Mineral Ownership, Dewey-Burdock Project Area (Continued)**

	Legal Description	Area (acres)	Surface Owner(s)	Mineral Owner(s)
<b>Township 7S, Range 1E, Fall River County, SD Black Hills Meridian</b>				
Section 10	SE $\frac{1}{4}$ SE $\frac{1}{4}$	40	Peterson & Son, Inc.	Agnes Medsker Irene R. Andersen Clint Andersen
Section 11	NE $\frac{1}{4}$ ; SE $\frac{1}{4}$ NW $\frac{1}{4}$ ; NE $\frac{1}{4}$ SW $\frac{1}{4}$ ; N $\frac{1}{2}$ SE $\frac{1}{4}$	320	Daniel Properties, LLC	BLM Minerals
	NE $\frac{1}{4}$ NW $\frac{1}{4}$	40	Daniel Properties, LLC	Daniel Properties, LLC
	W $\frac{1}{2}$ NW $\frac{1}{4}$ ; NW $\frac{1}{4}$ SW $\frac{1}{4}$	120	BLM	BLM Minerals
	SW $\frac{1}{4}$ SW $\frac{1}{4}$	40	Peterson & Son, Inc.	Agnes Medsker Irene R. Andersen Clint Andersen
	SE $\frac{1}{4}$ SW $\frac{1}{4}$ ; S $\frac{1}{2}$ SE $\frac{1}{4}$	120	Peterson & Son, Inc.	Peterson & Son, Inc. Black Stone Minerals Company, LP Jean Swirczynski Roy Guess
Section 12	N $\frac{1}{2}$ ; NW $\frac{1}{4}$ SW $\frac{1}{4}$	360	Carolyn Fines	BLM Minerals
	NE $\frac{1}{4}$ SW $\frac{1}{4}$	40	BLM	BLM Minerals
	S $\frac{1}{2}$ SW $\frac{1}{4}$ ; SE $\frac{1}{4}$	240	Everett and Dawn Englebert	BLM Minerals
Section 14	NE $\frac{1}{4}$ NE $\frac{1}{4}$ ; S $\frac{1}{2}$ NW $\frac{1}{4}$ NE $\frac{1}{4}$ ; SW $\frac{1}{4}$ NE $\frac{1}{4}$ ; S $\frac{1}{2}$ NE $\frac{1}{4}$ NW $\frac{1}{4}$ ; S $\frac{1}{2}$ NW $\frac{1}{4}$	200	Peterson & Son, Inc.	Peterson & Son, Inc.
	N $\frac{1}{2}$ NW $\frac{1}{4}$ NE $\frac{1}{4}$ ; N $\frac{1}{2}$ NE $\frac{1}{4}$ NW $\frac{1}{4}$	40	Peterson & Son, Inc.	Peterson & Son, Inc. Jean Swirczynski Roy Guess
	NW $\frac{1}{4}$ NW $\frac{1}{4}$	40	Peterson & Son, Inc.	Agnes Medsker Irene R. Andersen Clint Andersen
Section 15	NE $\frac{1}{4}$ NE $\frac{1}{4}$	40	Peterson & Son, Inc.	Agnes Medsker Irene R. Andersen Clint Andersen
	NW $\frac{1}{4}$ NE $\frac{1}{4}$ ; S $\frac{1}{2}$ NE $\frac{1}{4}$ ; NW $\frac{1}{4}$	280	Peterson & Son, Inc.	Peterson & Son, Inc. Black Stone Minerals Company, LP Jean Swirczynski Roy Guess

contains a monitoring and mitigation plan, and Section 6 describes plans for permit administration and reporting. A list of references is contained in Section 7. Supporting documentation is provided in the appendices.

## **1.1 Applicant Information**

The Inyan Kara water right application is submitted by Powertech (USA), which is the U.S.-based wholly owned subsidiary of the Powertech Uranium Corporation, a corporation registered in British Columbia. Powertech Uranium Corporation shares are publicly traded on the Toronto Stock Exchange (TSX) as PWE and the Frankfurt Stock Exchange as P8A. Powertech Uranium Corporation owns 100 percent of the shares of Powertech (USA). The corporate office of Powertech Uranium Corporation is located in Vancouver, British Columbia. Powertech (USA) is a U.S.-based corporation incorporated in the State of South Dakota.

The addresses and telephone numbers for the general office (Colorado) and the local office (South Dakota) of the applicant are listed as follows:

Name and address of applicant:

Company: Powertech (USA) Inc.  
Signatory: Richard Blubaugh  
Title: Vice President, Environmental Health & Safety Resources  
Address: 5575 DTC Parkway, Suite #140  
Greenwood Village, CO 80111  
Telephone: (303) 790-7528

Local representative or contact person:

Name: Mark Hollenbeck, P.E.  
Title: Project Manager  
Address: Powertech (USA) Inc.  
310 2<sup>nd</sup> Avenue  
P.O. Box 812  
Edgemont, SD 57735  
Telephone: (605) 662-8308

## 2.0 REQUESTED WATER APPROPRIATION

This section describes the purpose and need for the proposed water appropriation, the proposed facility design, proposed water usage, well construction details, and the project schedule.

### 2.1 Purpose and Need for Water Appropriation

The purpose of the water right application is to appropriate water from the Inyan Kara aquifer to be used beneficially for uranium mining using the ISR process. SDCL 46-2A-9 states the only conditions under which a permit to appropriate water may be issued:

Appropriation of water--When permit may be issued. A permit to appropriate water may be issued only if there is reasonable probability that there is unappropriated water available for the applicant's proposed use, that the proposed diversion can be developed without unlawful impairment of existing rights and that the proposed use is a beneficial use and in the public interest.

The first two parts of SDCL 46-2A-9 are addressed in Sections 4 and 5 of this report. Section 4 shows that adequate water is available in the Inyan Kara and that drawdown from net withdrawal of up to 170 gpm will result in minimal drawdown that will not impair existing rights.

ISR mining including groundwater restoration as a beneficial use of water is supported by SDCL 45-6B, which states, "Every effort should be used to promote and encourage the development of mining as an industry, but to prevent the waste and spoilage of the land and the improper disposal of tailings which would deny its future use and productivity." Additional support for uranium ISR to be considered a mining beneficial use is found in SDCL 45-6B-3(11), which includes *in situ* mining in the definition of "mining operation." SDCL 46-1-6(3) defines beneficial use as "any use of water within or outside the state, that is reasonable and useful and beneficial to the appropriator, and at the same time is consistent with the interests of the public of this state in the best utilization of water supplies." SDCL 46-1-8 defines beneficial use as "the basis, measure and limit of the right to the use of the waters [of the state]." The amount of water requested in this appropriation has been carefully determined by engineering analysis as the amount necessary to recover the uranium while protecting water resources outside the project area.

Powertech (USA)'s commitment to adhering to best professional practices, U.S. Nuclear Regulatory Commission (NRC) license conditions and EPA and DENR permit conditions will ensure that facility construction, operation, decommissioning and reclamation will protect DENR-approved postmining land uses. As required by the NRC license, various DENR permits and EPA Class III and V Underground Injection Control permits, Powertech (USA) will be

required to post financial assurance for all aspects of the Dewey-Burdock Project. This will ensure that resources will be available for decommissioning and reclamation such that the site will be released for unrestricted use. The amount of the financial assurance will include an amount sufficient to plug and abandon all wells constructed under this appropriation when these wells are no longer needed for the intended beneficial use.

The Dewey-Burdock Project NRC license application (Powertech, 2009) describes how the project benefits include its potential to create approximately 250 new jobs during construction and approximately 150 new jobs during operation, which will contribute direct and indirect benefits to the local economy. In addition, Powertech (USA) estimates that the project will generate some \$35 million in state and local tax revenue and approximately \$187 million in value added benefits over the life of the project.

## **2.2 Project Overview**

The Dewey-Burdock Project is a proposed uranium ISR project. The uranium will be recovered by injecting groundwater fortified with oxidizing and complexing agents (oxygen and carbon dioxide) into a series of injection wells. The oxidized water will dissolve uranium and will be pumped by submersible pumps to the surface, where the uranium will be recovered via ion exchange and processed into the final product (yellowcake). After the uranium is removed, the groundwater will be refortified with oxygen and carbon dioxide and recirculated through the well fields. The uranium mineralization targeted for production is contained within the Inyan Kara Group, specifically within the Fall River Formation and Chilson Member of the Lakota Formation.

The eastern portion of the project area is called the Burdock area. It will include a series of ISR well fields and a central processing plant (CPP), which will be used to recover uranium from the Burdock well fields using ion exchange and to process the uranium-loaded ion exchange resin. The western portion of the project area is called the Dewey area. It will include a series of ISR well fields and a satellite plant, which will be used to recover uranium from the Dewey well fields using ion exchange. The uranium-loaded ion exchange resin will be transported from the satellite facility to the CPP for processing. Processing will include stripping the uranium from the loaded resin using a saltwater solution (elution), precipitating the dissolved uranium to form an insoluble uranium oxide (precipitation), and filtering, washing, drying, and packaging the dried uranium oxide product (yellowcake) into sealed containers.

Each ISR well field will be operated until uranium recovery is no longer economical. Powertech (USA) estimates that individual well field operating lives will be about 2 years, with multiple



well fields typically in operation at any given time. Aquifer restoration will be completed following uranium recovery in each well field. During aquifer restoration, the groundwater in the well field will be restored in accordance with NRC requirements. The primary goal of aquifer restoration will be to restore the groundwater to baseline (background) or a maximum containment level (MCL), whichever is higher.

The vast majority of the water withdrawn from the Inyan Kara aquifer will be reinjected as part of the ISR process. In fact, the planned net withdrawal rate will be only about 2% of the gross pumping rate. The net Inyan Kara water usage will depend on the method of liquid waste disposal. Powertech (USA) proposes two options for liquid waste disposal at the Dewey-Burdock Project. The preferred disposal option is underground injection of treated liquid waste in Class V deep disposal wells (DDWs). In this disposal option liquid waste will be treated to meet EPA non-hazardous waste criteria and injected into the Minnelusa and/or Deadwood Formations in four to eight DDWs, which are being permitted pursuant to the Safe Drinking Water Act through the EPA Underground Injection Control Program. It is anticipated that all liquid waste will be disposed using this option if sufficient capacity is available in DDWs, which will not be known until test wells are completed.

In the DDW option, aquifer restoration will be carried out by treating the water pumped from the production wells using reverse osmosis (RO) and injecting the high quality permeate into the injection wells. The RO reject (brine) will be disposed in the DDWs.

The alternate liquid waste disposal option is land application. This option involves treatment in lined settling ponds followed by seasonal application of treated liquid waste through center pivot sprinklers. The size of each of two proposed land application areas will be 315 acres, plus 65 acres at each site as standby for contingencies. The total land application area could thus be as much as 760 acres. Land application would be carried out under a groundwater discharge plan, which is currently being permitted through DENR. Depending on the availability and capacity of DDWs, Powertech (USA) may use land application in conjunction with DDWs or by itself.

In the land application option, aquifer restoration will be carried out by injecting relatively high quality water from the Madison Limestone into the injection wells. Water withdrawn from the Inyan Kara production wells in this option will be treated and disposed in the land application systems.

Domestic wastewater from restrooms in the processing facilities will be disposed in septic systems permitted through DENR and/or Custer and Fall River counties and will not be disposed through deep disposal wells or land application.

### 2.3 Appropriation Volume

ISR circulates significant quantities of water through the ore zone. Only a small fraction of that water is a net withdrawal because most water is recirculated through the deposit. During ISR operations (including both production and restoration), a small portion of the solution extracted from the aquifer will be “bled” from the system. Bleed is defined as excess production or restoration solution withdrawn to maintain a cone of depression so native groundwater continually flows toward the center of the production zone. This bleed constitutes the net water withdrawal from the Inyan Kara aquifer. Nominal bleed rates of 0.5 to 1 percent are planned over the life of the project. If necessary, additional bleed (up to 17%) will be used briefly during aquifer restoration to recover additional solutions and draw a greater influx of water into the ore zone from the surrounding Inyan Kara aquifer. This is known as groundwater sweep.

Table 2-1 summarizes the anticipated maximum Inyan Kara water usage and requested appropriation amount for the entire Dewey-Burdock Project. During uranium recovery (production), Powertech (USA) plans to pump up to 8,000 gpm from the Inyan Kara aquifer. The typical production bleed rate will be 0.875%. Therefore, the net production withdrawal will typically be up to 70 gpm. During aquifer restoration, Powertech (USA) proposes to pump up to 500 gpm from the Inyan Kara aquifer. The restoration bleed will vary from about 1% to 17%. Therefore, the net aquifer restoration withdrawal will be up to 85 gpm. During concurrent production and restoration, the anticipated maximum gross and net usage from the Inyan Kara (on an annual average basis) will be 8,500 gpm and 155 gpm, respectively. The 8,500 gpm (18.938 cfs or 13,710.6 ac-ft/yr) is the amount of appropriation requested on Form 2 (Item 2), but the net withdrawal rate (also shown on Form 2) will be a small fraction of this amount.

The instantaneous production bleed rate may vary in the range of 0.5 to 3 percent for short durations, from days to months. The maximum production bleed would typically only be used temporarily to correct any well field imbalance. To allow for operational flexibility, Powertech (USA) is requesting a permitted maximum net withdrawal rate of 274.2 ac-ft/yr, which is equivalent to an annual average net withdrawal rate of 0.38 cfs or 170 gpm. This is conservatively based on the maximum gross withdrawal rate of 8,500 gpm (18.938 cfs) with a 2% overall bleed. Table 2-1 demonstrates that the vast majority of Inyan Kara water withdrawn during production and restoration will be concurrently reinjected into the well fields, such that the proposed net appropriation amount is only 2% of the proposed gross appropriation amount.

**Table 2-1: Maximum Anticipated Inyan Kara Water Usage and Requested Appropriation Amount**

<b>Usage</b>	<b>Amount</b>
<b>Production Only</b>	
Gross Inyan Kara Pumping, gpm	8,000
Net Inyan Kara Usage (0.875% bleed), gpm	70
<b>Aquifer Restoration Only</b>	
Gross Inyan Kara Pumping, gpm	500
Net Inyan Kara Usage (1% bleed), gpm	5
Net Inyan Kara Usage (17% bleed), gpm	85
<b>Concurrent Production and Restoration</b>	
Gross Inyan Kara Pumping, gpm	8,500
Net Inyan Kara Usage (1% aquifer restoration bleed), gpm	75
Net Inyan Kara Usage (17% aquifer restoration bleed), gpm	155
Proposed Maximum Annual Average Gross Pumping Rate, gpm	8,500
Proposed Maximum Annual Average Net Withdrawal Rate, gpm	170
<b>Proposed Appropriation Amount (Gross), ac-ft/yr</b>	13,710.6
<b>Proposed Appropriation Amount (Net), ac-ft/yr</b>	274.2

## 2.4 Groundwater Withdrawal System

### 2.4.1 Approach to Well Field Development

Each ISR well field will consist of a series of injection and production wells completed within the target mineralization zone. Prior to design and layout of the wells, the ore bodies will be delineated with exploration holes drilled on approximately 100-foot centers. These holes will be geologically and geophysically logged. Before drilling, each injection and production well will be assigned lateral coordinates, a ground surface elevation, depth to top of screened interval, and length of screened interval.

For all injection and production wells, the top of the screened interval will be at or below the base of the confining unit overlying the mineralized zone. The screened interval will be completed only across the targeted ore zone.

A typical (100 x 100-foot grid) well field layout is illustrated on Plate 2-1. This typical layout is based on the lateral distribution and grade of one of the uranium deposits within the project area.

The well patterns may differ from well field to well field, but a typical pattern will consist of five wells, with one well in the center and four wells surrounding it oriented in four corners of a square measuring between 50 and 150 feet on a side. Typically, a production well will be located in the center of the pattern, and the four corner wells will be injection wells. The pattern

dimensions will be modified as needed to fit the characteristics of each ore body. Other well field designs that may be considered include alternating single lines of production and injection wells.

All wells will be completed for use as either injection or production wells, so that flow patterns can be changed as needed to recover uranium and restore groundwater quality in the most efficient manner.

Figure 2-1 depicts the approximate project ore bodies proposed for uranium recovery and shows all lower Fall River ore bodies in blue, all ore bodies within the upper Chilson Member of the Lakota Formation in green and middle/lower Chilson ore bodies in red. The limits of the ore bodies are tentative at this time and will be delineated through drilling on 100-foot centers. Therefore, Powertech (USA) proposes to include the entire project area as the Inyan Kara diversion area as shown on Figure 1-2. All well fields and perimeter monitor wells will be located within the NRC license boundary/LSM permit boundary.

Production and injection wells will be connected to a header house, as shown on Plate 2-2. Wellhead connection details for injection and production wells are illustrated on Figures 2-2 and 2-3, respectively. Typically, one header house will service up to 20 production wells and 80 injection wells. Piping between the wells and header house will consist of high density polyethylene (HDPE) pipe with heat-welded joints, buried at least 5 feet below grade. The piping will withstand operating pressures of 150 psig, but actual pressures will typically be less than 100 psig. The piping will terminate at the header house where it will be connected to manifolds equipped with control valves, flow meters, check valves, pressure sensors, oxygen and carbon dioxide feed systems (injection only), and programmable logic controllers. Electrical power to the header houses will be delivered via overhead power lines and via buried cable. Figures 2-4 and 2-5 depict the proposed facilities and potential initial well field areas in the land application and deep disposal well options, respectively. Electrical power to individual wells will be delivered via buried cable from the header house.

As a well field expands, additional header houses will be constructed. They will be connected to one another via buried piping that is sized to accommodate the necessary injection and production flow rates and pressures. In turn, header pipes from entire well fields will be connected to either the satellite facility or CPP. A piping detail that shows the connection between the main header piping and laterals to header houses is shown on Plate 2-2.

Monitor wells will be positioned around the perimeter of each well field ring and internal to each well field, as illustrated on Plate 2-1. Perimeter wells will be screened across the entire production zone to monitor for any potential lateral excursion within the zone outside the well

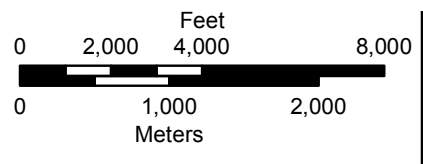
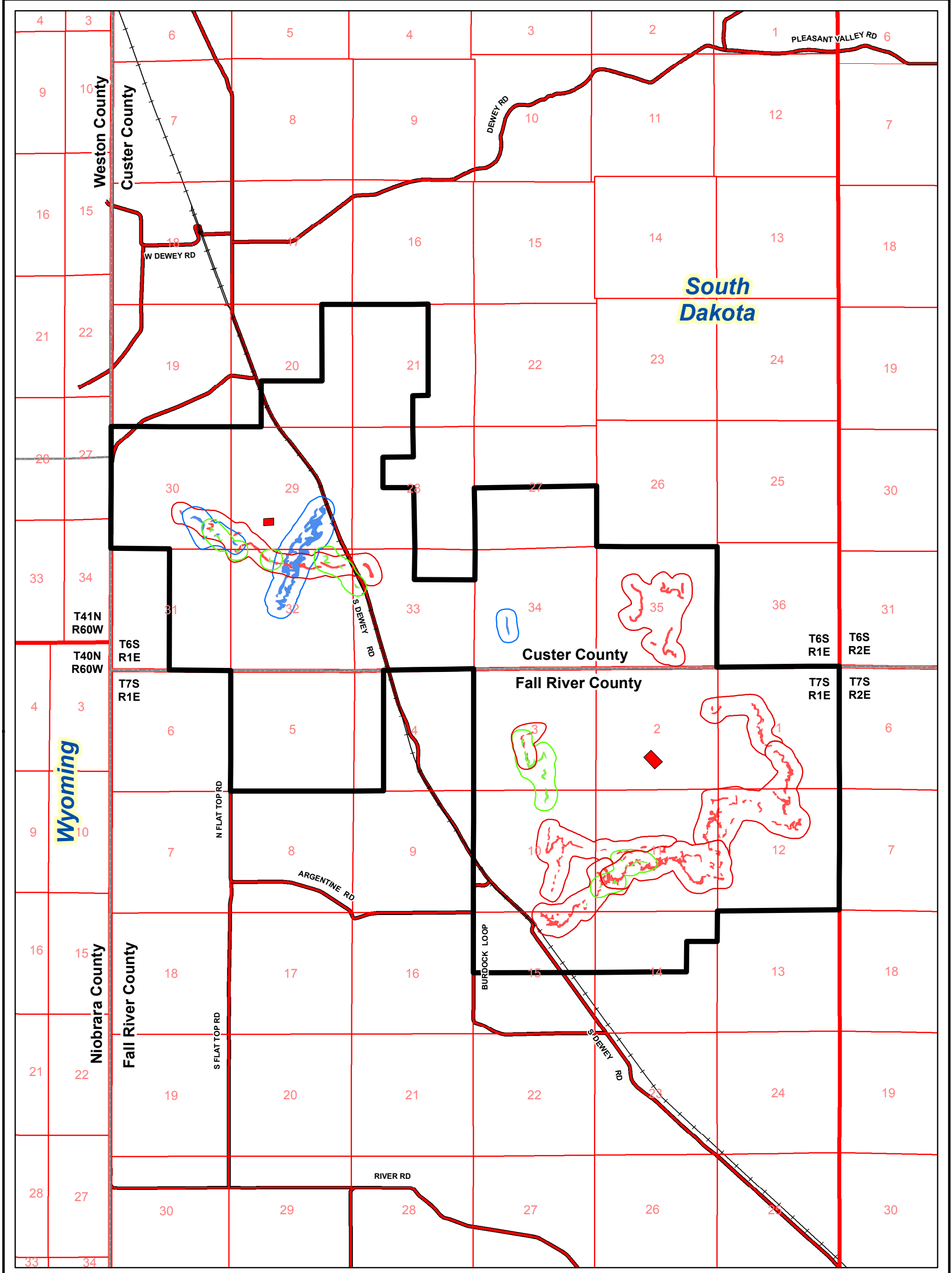

- Legend**
- |                   |                            |                      |
|-------------------|----------------------------|----------------------|
| Project Boundary  | Potential Well Field Areas | Ore Bodies           |
| Processing Plants | Lower Fall River           | Lower Fall River     |
| BNSF Railroad     | Upper Chilson              | Upper Chilson        |
| County Roads      | Middle/Lower Chilson       | Middle/Lower Chilson |

**Figure 2-1**  
Potential Well Field Areas

Dewey-Burdock Project

DRAWN BY	S. Hetrick
DATE	29-May-2012
FILENAME	WF-PotentialConfig.mxd

**POWERTECH (USA) INC.**

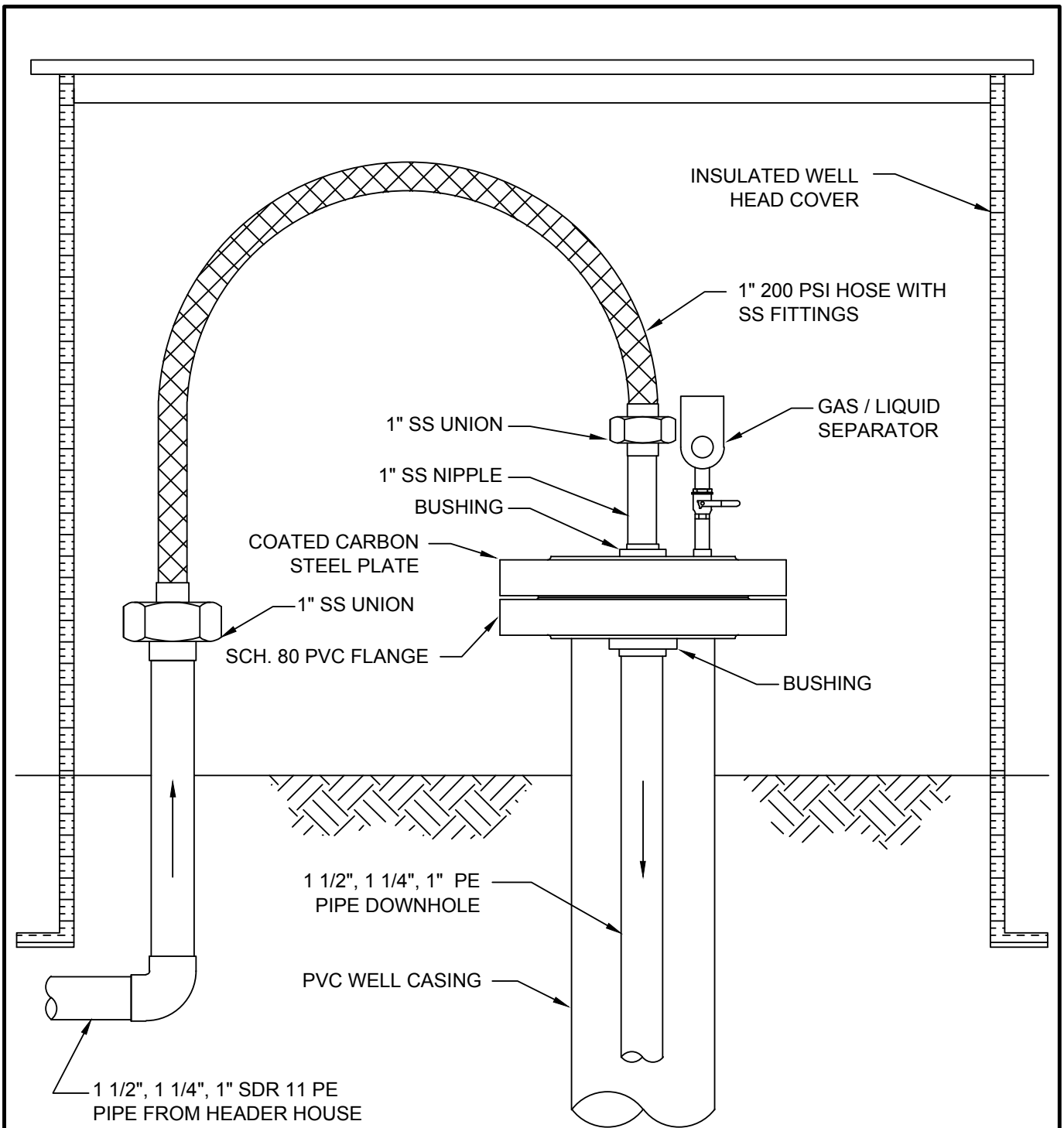

**Figure 2-2**

Typical Injection Wellhead

Dewey-Burdock Project

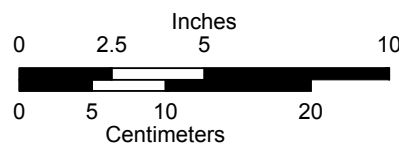

DRAWN BY Cadd Svcs

DATE 29-May-2012

FILENAME Wells-InjWellhead.dwg



**POWERTECH (USA) INC.**

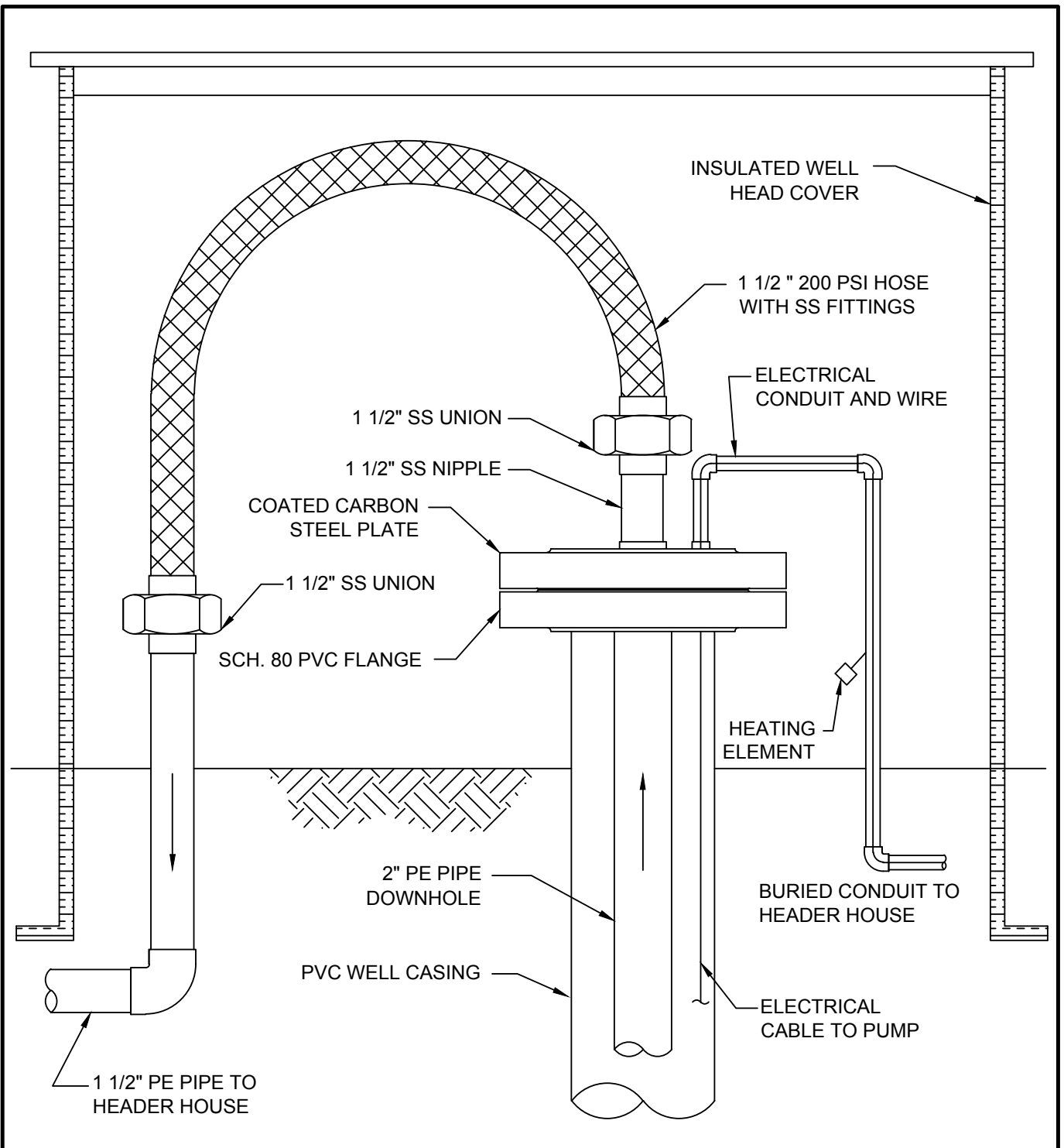

**Figure 2-3**

Typical Production Wellhead

Dewey-Burdock Project

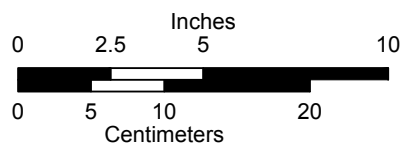

DRAWN BY	Cadd Svcs
DATE	29-May-2012
FILENAME	Wells-ProdWellhead.dwg



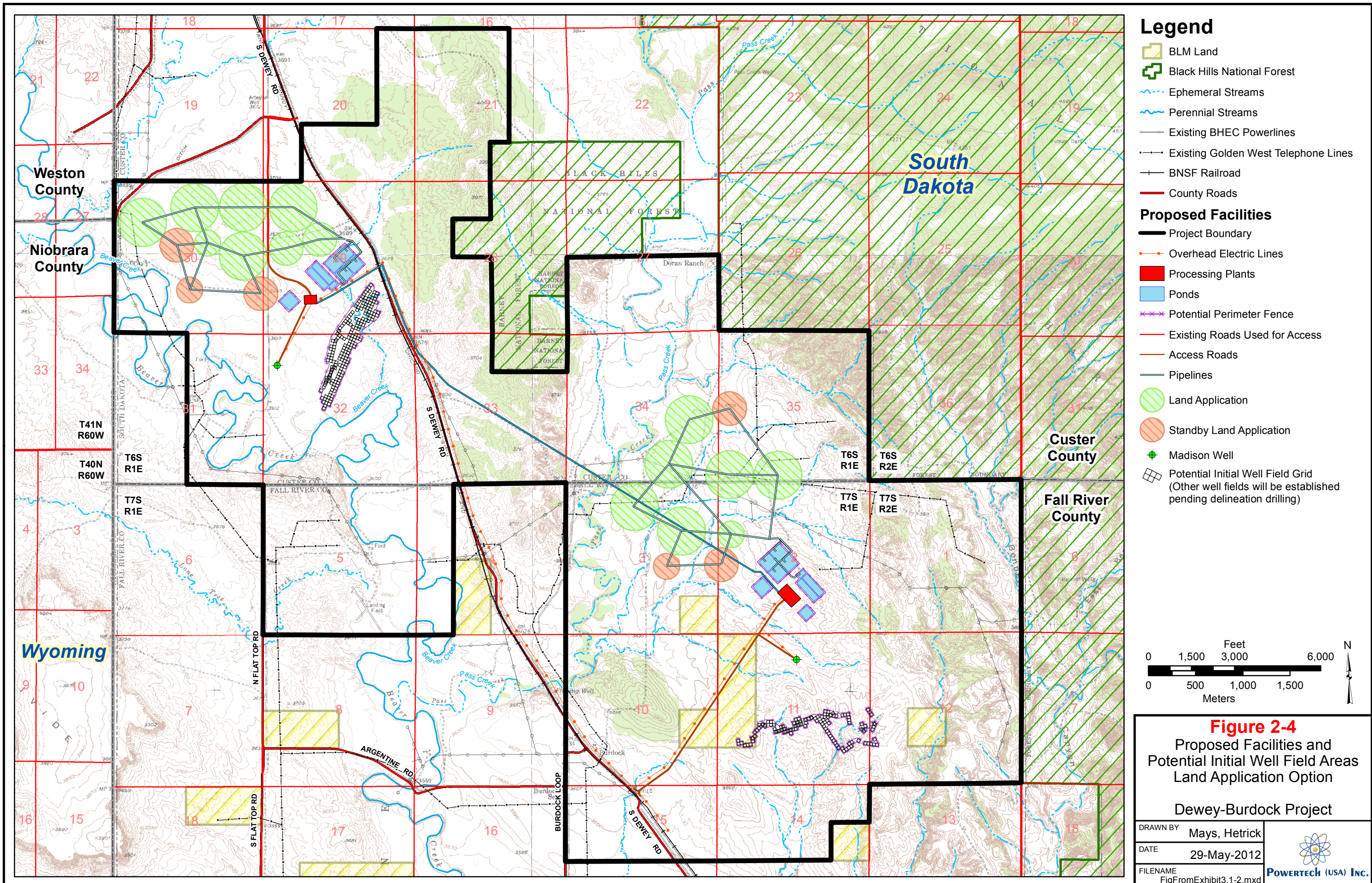

**Legend**

- BLM Land
- Black Hills National Forest
- Ephemeral Streams
- Perennial Streams
- Existing BHEC Powerlines
- Existing Golden West Telephone Lines
- BNSF Railroad
- County Roads
- Proposed Facilities**
- Project Boundary
- Overhead Electric Lines
- Processing Plants
- Ponds
- Potential Perimeter Fence
- Existing Roads Used for Access
- Access Roads
- Pipelines
- Land Application
- Standby Land Application
- Madison Well
- Potential Initial Well Field Grid  
(Other well fields will be established pending delineation drilling)

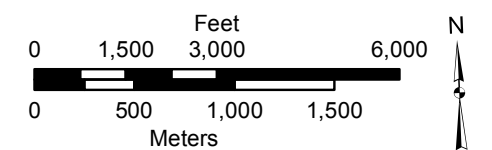
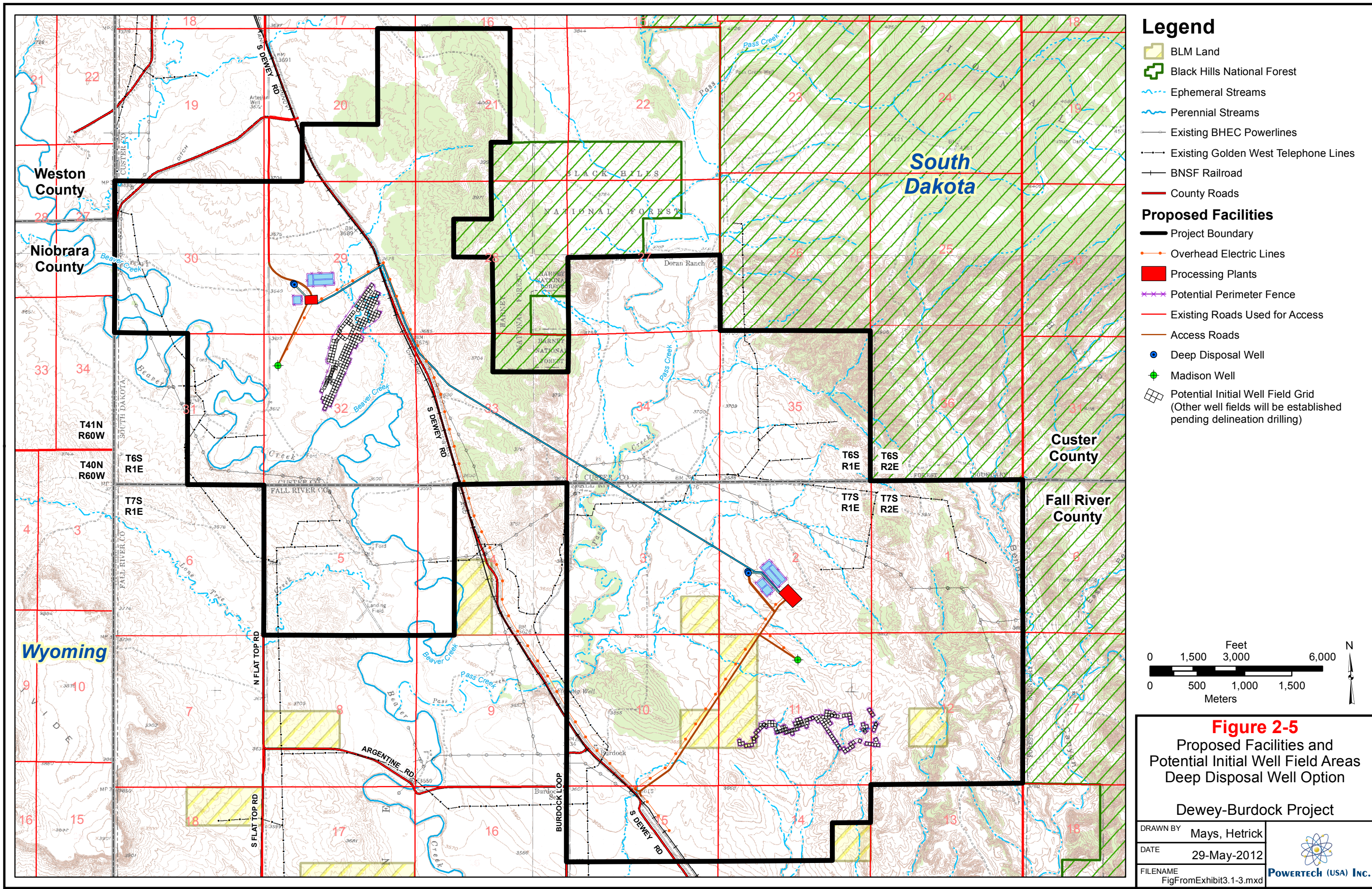

**Figure 2-4**  
Proposed Facilities and  
Potential Initial Well Field Areas  
Land Application Option

Dewey-Burdock Project

DRAWN BY	Mays, Hetrick	 <b>POWERTECH (USA) INC.</b>
DATE	29-May-2012	
FILENAME	FigFromExhibit3.1-2.mxd	





**Legend**

- BLM Land
  - Black Hills National Forest
  - Ephemeral Streams
  - Perennial Streams
  - Existing BHEC Powerlines
  - Existing Golden West Telephone Lines
  - BNSF Railroad
  - County Roads
- Proposed Facilities**
- Project Boundary
  - Overhead Electric Lines
  - Processing Plants
  - Potential Perimeter Fence
  - Existing Roads Used for Access
  - Access Roads
  - Deep Disposal Well
  - Madison Well
  - Potential Initial Well Field Grid (Other well fields will be established pending delineation drilling)

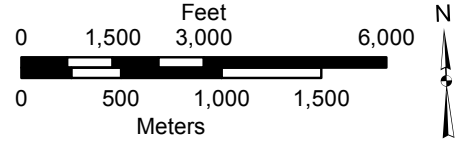

**Figure 2-5**  
Proposed Facilities and Potential Initial Well Field Areas Deep Disposal Well Option

<b>Dewey-Burdock Project</b>	
DRAWN BY	Mays, Hetrick
DATE	29-May-2012
FILENAME	FigFromExhibit3.1-3.mxd

field and to demonstrate compliance with groundwater quality standards within this zone. Internal monitor wells will be screened across the overlying and underlying aquifers, respectively.

#### ***2.4.2 Well Field Development Schedule***

Following the issuance of an NRC uranium recovery license, DENR LSM permit, and other required permits, construction will commence on the first well fields, CPP and/or satellite facility and ancillary facilities including storage ponds and land application pivots and/or deep disposal wells. Powertech (USA) may develop either the Burdock or Dewey area well fields first, followed by the well fields in the other area, or well fields may be developed simultaneously in the Burdock and Dewey portions of the project area. Uranium recovery operations will continue for approximately 7 to 20 years during which additional well fields will be completed along the roll fronts. During this operational period, Powertech (USA) anticipates that the water right permit will be administratively modified as necessary to account for changes in the diversion locations (production wells) and subject to DENR permit renewal procedures. Following operation, aquifer restoration will restore groundwater quality. The entire Dewey-Burdock Project will then be decommissioned and reclaimed in accordance with NRC and DENR requirements. The projected construction, operation, restoration and decommissioning schedule is provided in Figure 2-6.

Figure 2-7 depicts the anticipated construction schedule for the production wells in the Dewey portion of the project area. Powertech (USA) anticipates that up to about 600 ISR production wells will be constructed over approximately an 8-year timespan in the Dewey portion of the project area.

Figure 2-8 depicts the anticipated production well construction schedule in the Burdock portion of the project area. Powertech (USA) anticipates that up to about 900 ISR production wells will be constructed over approximately an 8-year timespan in the Burdock portion of the project area.

The construction schedules depicted in Figures 2-7 and 2-8 are the anticipated schedules based on currently identified well field areas and current mine planning. These schedules are consistent with the project schedule presented in the NRC license application and represent Powertech (USA)'s best estimate, which is based on exploration drilling and evaluation of data from approximately 3,900 exploration holes. A number of factors may change the actual well field development schedule, including but not limited to future exploration and well field delineation within the project area and production performance within well fields. While the currently

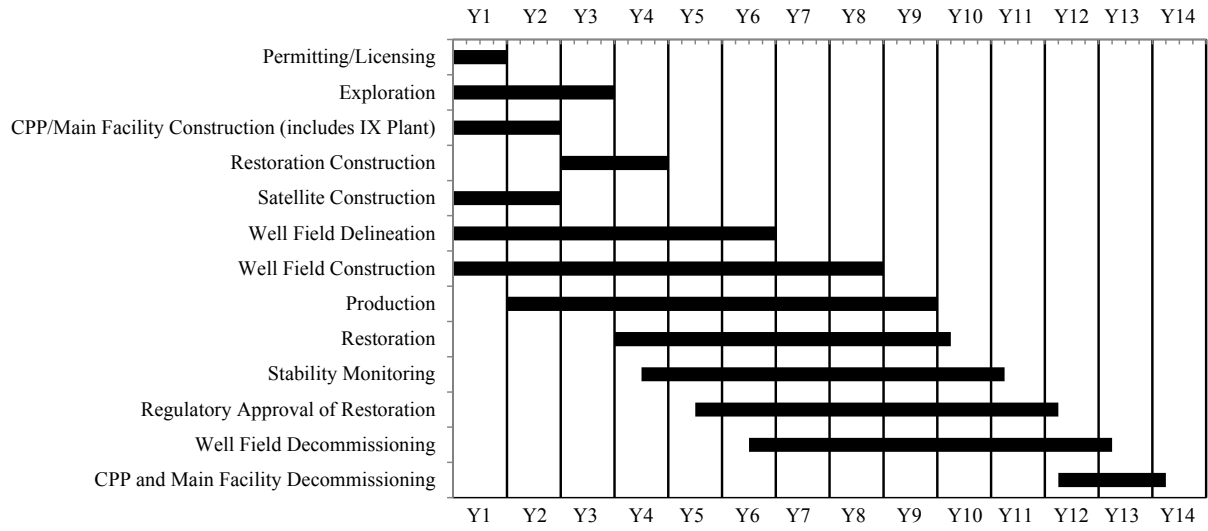

**Figure 2-6: Projected Construction, Operation, Restoration and Decommissioning Schedule**

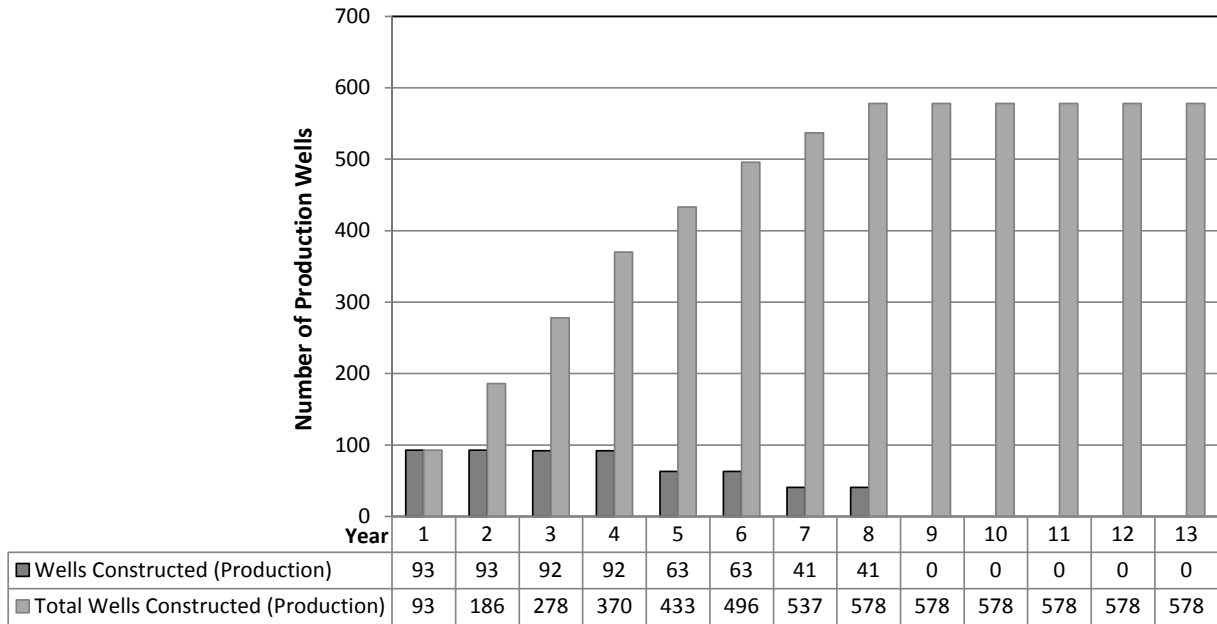

**Figure 2-7: Anticipated Production Well Construction Schedule - Dewey Portion of the Project Area**

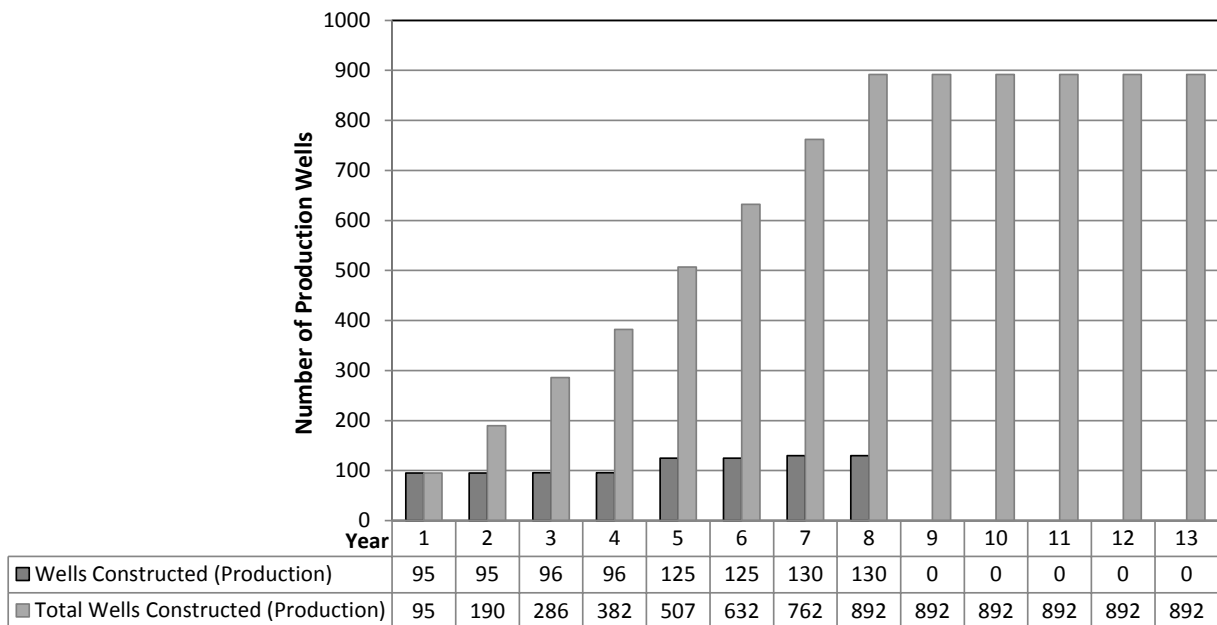

**Figure 2-8: Anticipated Production Well Construction Schedule - Burdock Portion of Project Area**

anticipated well field development schedules reflect simultaneous development of the Dewey and Burdock well fields, Powertech (USA) may develop the well fields in one portion of the project area first and then develop the well fields in the other portion of the project area. Additional exploration drilling could also lead to installation of additional well fields within the project area, which could extend the construction schedule.

Based on the currently anticipated construction schedule of approximately 8 years and the potential that this schedule would be extended, Powertech (USA) anticipates requesting an extension of the construction period pursuant to SDCL 46-5-26 prior to the conclusion of the 5-year construction period set forth in SDCL 46-2A-8 after the water right is issued. Specifically, Powertech (USA) anticipates filing a permit amendment for an extension of time and a variance from SDCL 46-2A-8, which specifies that, “Any construction necessary to put the water to beneficial use shall be completed within five years of approval of the permit and the water shall be put to beneficial use within an additional four years.” The proposed maximum gross and net withdrawal rates would not increase due to a change in schedule.

### ***2.4.3 Well Construction and Integrity Testing***

Well construction materials, methods, development, and integrity testing are described in the following subsections. All ISR production and injection wells will be completed in accordance with South Dakota well construction standards and EPA standards for Class III Underground Injection Control wells.

#### **2.4.3.1 Well Construction Materials**

Well casing material will typically be thermoplastic such as polyvinyl chloride (PVC) with at least SDR 17 wall thickness. The wells will typically be 4.5 to 6-inch nominal diameter which meets or exceeds the specifications of ASTM Standard F480 and NSF Standard 14. In order to provide an adequate annular seal, the drill hole diameter will be at least 2 inches greater than the outside diameter of the well casing. This minimum distance between the drill hole wall and the well casing will be maintained regardless of casing diameters utilized.

The annulus will be pressure-grouted and sealed with neat cement grout. Cement grout will be composed of highly sulfate-resistant Portland cement with a slurry weight of approximately 11 pounds per gallon. Water used to make the cement grout will not contain oil or other organic material. Cement grout could contain adequate bentonite to maintain the cement in suspension in accordance with Halliburton cement tables.

Casing will be joined using methods recommended by the casing manufacturer. PVC casing joints approximately 20 feet apart will be joined mechanically (with a watertight O-ring seal and a high strength nylon spline) to ensure watertight joints above the perforations or screens. Casings and annular material will be routinely inspected and maintained throughout the operating life of the wells.

#### **2.4.3.2 Well Construction Methods**

Well installation will begin by drilling a pilot bore hole through the ore zone to obtain a measurement of the uranium grade and the depth. The depth of ore targeted for ISR ranges from 200 to 800 feet. This represents the range of anticipated well depths. The pilot bore hole will be geologically and geophysically logged. After logging, the pilot bore hole will be reamed to the appropriate diameter to the top of the ore zone. A continuous string of PVC casing will be placed into the reamed borehole. Casing centralizers will be installed as appropriate. With the casing in place a cement/bentonite grout will be pumped into the casing. The grout will circulate out the bottom of the casing and up the casing annulus to the ground surface. The volume of grout necessary to cement the annulus will be calculated from the bore hole diameter of the casing with sufficient additional allowance to achieve grout returning to surface. Grout remaining inside the well casing may be displaced by water or heavy drill mud to minimize the column of the grout plug remaining inside the casing. Care will be taken to assure that a grout plug remains inside the casing at completion. The casing and grout will then be allowed to set undisturbed for a minimum of 24 hours. When the grout has set, if the annular seal observed from the ground surface has settled below the ground surface, additional grout will be placed into the annular space to bring the grout seal to the ground surface.

After the 24-hour (minimum) setup period, a drill rig will be mobilized to finish well construction by drilling through the grout plug and through the mineralized zone to the specified total well depth. As illustrated in Figure 2-9, the open borehole will then be underreamed to a larger diameter.

A well screen assembly will then be lowered through the casing into the open hole. The top of the well screen assembly will be positioned inside the well casing and centralized and sealed inside the casing using K packers. With the drill pipe attached to the well screen, a 1-inch diameter tremmie pipe will be inserted through drill pipe and screen and through the sand trap check valves at the bottom of well screen assembly. Filter sand, comprised of well-rounded silica sand sized to optimize hydraulic communication between the target zone and well screen, will

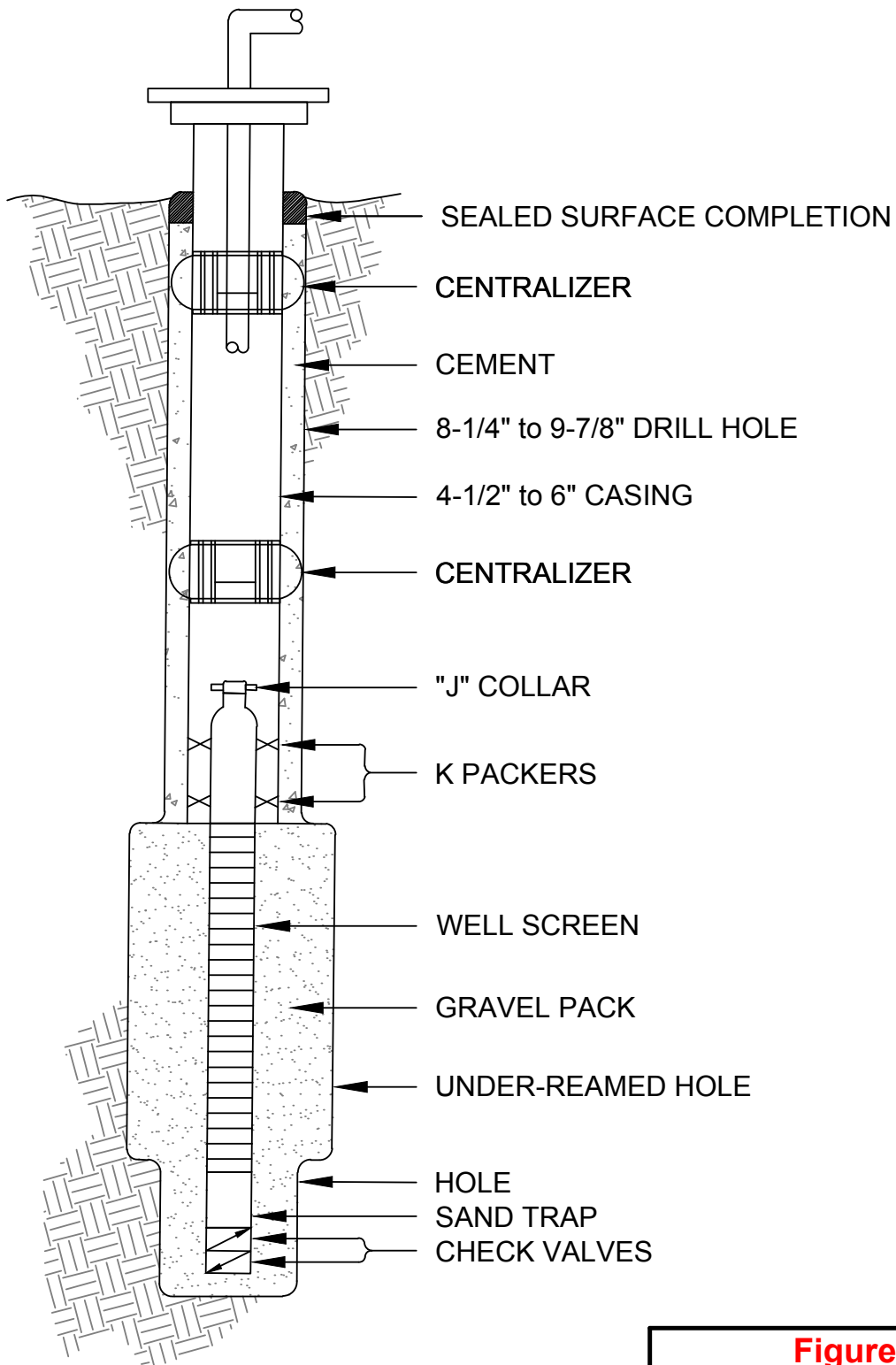

**Figure 2-9**

Typical Well Construction

Dewey-Burdock Project

DRAWN BY L. Tafoya

DATE 29-May-2012

FILENAME Wells-TypConstruction.dwg



**POWERTECH (USA) INC.**

then be placed between the well screen and the formation. The volume of sand introduced will be calculated as the amount that it fills the annular space. The sand will not extend upward beyond the K packers due to packer design. A well completion report will then be prepared for each well and filed with the DENR. Copies of the reports will be kept available on site for review and will be submitted to other regulatory agencies upon request.

#### **2.4.3.3 Well Development**

The primary goals of well development will be to allow formation water to enter the well screen, flush out drilling fluids, and remove the finer clays and silts to maximize flow from the formation through the well screen. This process is necessary to allow representative samples of groundwater to be collected, if applicable, and to ensure efficient injection and production operations. Wells will be developed immediately after construction using air lifting, swabbing, pumping or other accepted development techniques which will remove water and drilling fluids from the casing and borehole walls along the screened interval. Prior to obtaining baseline samples from monitor or restoration wells, additional well development will be conducted to ensure that representative formation water is sampled. The water will be pumped sufficiently to show stabilization of pH and conductivity values prior to sampling to demonstrate that development activities have been effective.

#### **2.4.3.4 Well Integrity Testing**

All injection, production, and monitor wells will be field tested to demonstrate the mechanical integrity of the well casing. The mechanical integrity testing (MIT) will be performed using pressure-packer tests. The bottom of the casing will be sealed with a plug, downhole inflatable packer, or other suitable device. The casing will be filled with water and the top of the casing will be sealed with a threaded cap, mechanical seal or downhole inflatable packer. The well casing then will be pressurized with water or air and monitored with a calibrated pressure gauge. Internal casing pressure will be increased to 125 percent of the maximum operating pressure of the well field, 125 percent of the maximum operating pressure rating of the well casing (which is always less than the maximum pressure rating of the pipe), or 90 percent of the formation fracture pressure (which equates to approximately 1 psi per foot of overburden above the bottom of casing), whichever is less. A well must maintain 90 percent of this pressure for a minimum of 10 minutes to pass the test.

If there are obvious leaks, or the pressure drops by more than 10 percent during the 10-minute period, the seals and fittings on the packer system will be checked and/or reset and another test



will be conducted. If the pressure drops less than 10 percent the well casing will have demonstrated acceptable mechanical integrity.

If a well casing does not meet the MIT criteria, the well will be removed from service. The casing may be repaired and the well re-tested, or the well may be plugged and abandoned. Any well permanently taken out of service and abandoned will be plugged in accordance with South Dakota standards in ARSD 74:02:04:67. If a repaired well passes the MIT, it will be employed in its intended service. If an acceptable test cannot be demonstrated following repairs, the well will be plugged and abandoned.

In addition to the integrity testing of new wells, MIT will be conducted on any well following any repair where a downhole drill bit or under-reaming tool is used. Any well with evidence of subsurface damage will require a new MIT prior to the well being returned to service. MIT will also be repeated once every five years for all active wells.

MIT documentation will include the well designation, date of test, test duration, beginning and ending pressures, and the signature of the individual responsible for conducting the test. Results of the MIT will be maintained on-site and will be available for inspection by regulatory agencies.

## 2.5 Diversion Area

Figure 1-2 depicts the proposed groundwater diversion area. The legal description of the diversion area follows:

### Custer County, South Dakota

#### Township 6 South, Range 1 East, Black Hills Meridian:

Section 20: E $\frac{1}{2}$ NE $\frac{1}{4}$ ; E $\frac{1}{2}$ SE $\frac{1}{4}$ ; SW $\frac{1}{4}$ SE $\frac{1}{4}$ ; S $\frac{1}{2}$ NW $\frac{1}{4}$ SE $\frac{1}{4}$ ; SE $\frac{1}{4}$ SW $\frac{1}{4}$ ; and S $\frac{1}{2}$ NE $\frac{1}{4}$ SW $\frac{1}{4}$

Section 21: W $\frac{1}{2}$ ; W $\frac{1}{2}$ W $\frac{1}{2}$ NE $\frac{1}{4}$ ; W $\frac{1}{2}$ NW $\frac{1}{4}$ SE $\frac{1}{4}$

Section 27: S $\frac{1}{2}$

Section 28: N $\frac{1}{2}$ NW $\frac{1}{4}$ ; SW $\frac{1}{4}$ NW $\frac{1}{4}$ ; SW $\frac{1}{4}$

Section 29

Section 30

Section 31: E $\frac{1}{2}$

Section 32

Section 33: NW $\frac{1}{4}$ ; SW $\frac{1}{4}$ ; SE $\frac{1}{4}$ ; S $\frac{1}{2}$ NE $\frac{1}{4}$

Section 34

Section 35



**Fall River County, South Dakota**

**Township 7 South, Range 1 East, Black Hills Meridian:**

Section 1

Section 2

Section 3

Section 4:  $W\frac{1}{2}W\frac{1}{2}$

Section 5

Section 10

Section 11

Section 12

Section 14:  $NW\frac{1}{4}; W\frac{1}{2}NE\frac{1}{4}; NE\frac{1}{4}NE\frac{1}{4}$

Section 15:  $N\frac{1}{2}$

## **3.0 HYDROGEOLOGIC SETTING**

### **3.1 Geology**

The project area is located in the Great Plains Physiographic province on the southwestern flank of the Black Hills Uplift in southwestern South Dakota. To the west of the project area is the Powder River Basin of Wyoming. The regional geologic map is shown in Figure 3-1.

#### ***3.1.1 Regional Geology***

##### **3.1.1.1 Regional Structure**

The dominant structural feature in this region is the Black Hills Uplift. This uplift is of Laramide age (65 million years ago) and is an elongate northwest trending dome about 125 miles long and 60 miles wide. Igneous and metamorphic Precambrian-age rocks are exposed in the core of the uplift and are surrounded by outward-dipping Paleozoic and Mesozoic rocks that form cuestas and hogbacks around the core of the uplift. Folds constitute the major structural features in the Black Hills. In early Cretaceous time minor deformation along concealed northeast-trending structures of Precambrian age affected the courses of the northwest-flowing streams and their tributaries, influencing the locations of the fluvial sandstone deposits of the Inyan Kara Group.

##### **3.1.1.2 Regional Stratigraphy**

The oldest rocks in the region are Precambrian metamorphic rocks and granites. These form the core of the Black Hills Uplift and are exposed at the surface in the center of this structural feature. Overlying these crystalline rocks as one moves radially outward from the core of the uplift are up to 2,000-3,000 feet of Paleozoic sediments. This sedimentary sequence contains several regional aquifers, including the Deadwood Formation of Cambrian age, the Mississippian Madison Limestone and the Pennsylvanian/Permian-age Minnelusa Formation.

Mesozoic sediments include the Triassic age Spearfish Formation and the Sundance Formation, Unkpapa Sandstone, and Morrison Formation of Jurassic age. The Sundance Formation is a minor aquifer in the southern Black Hills region. A thick sequence of Cretaceous-age sediments completes the Mesozoic section.

The Early Cretaceous sediments of the Inyan Kara Group consist of the Lakota Formation and the Fall River Formation. The Inyan Kara Group is a transitional unit, exhibiting a change from terrestrial to marine deposition. The basal Lakota Formation (Chilson Member) is a fluvial

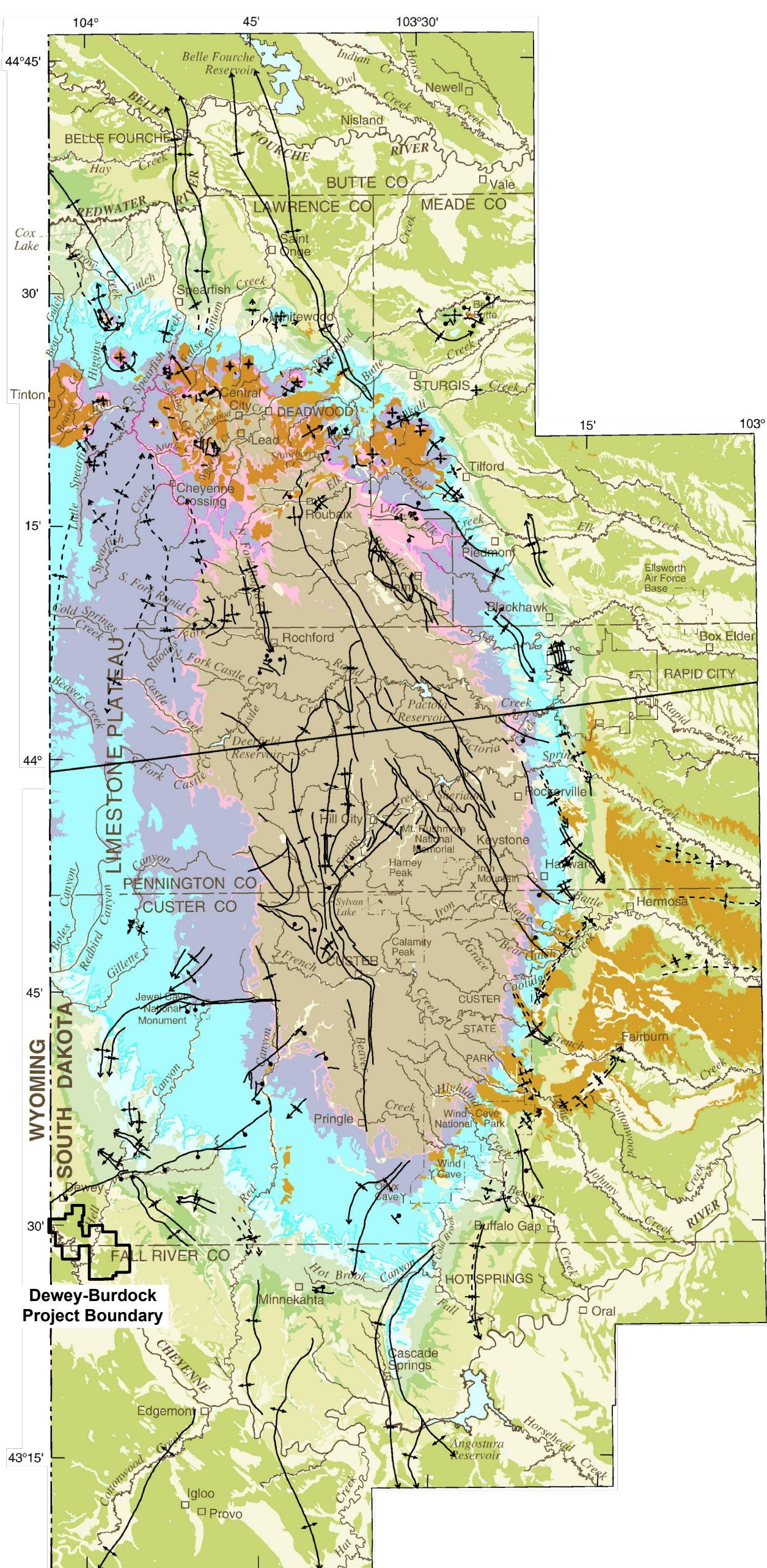

HYDRO- GEOLOGIC UNITS	STRATI- GRAPHIC UNITS	MAP UNITS	EXPLANATION
Unconsolidated units	Q <sub>Tac</sub>		Alluvium, terraces, and colluvium, undifferentiated
White River aquifer	T <sub>w</sub>		White River Group
Tertiary intrusive units	T <sub>ul</sub>		Undifferentiated intrusive igneous rocks
Cretaceous-sequence confining unit	K <sub>ps</sub>		Pierre Shale to Skull Creek Shale, undifferentiated
Inyan Kara aquifer	K <sub>ik</sub>		Inyan Kara Group
Jurassic-sequence semiconfining unit	J <sub>u</sub>		Morrison Formation to Gypsum Spring Formation, undifferentiated
Spearfish confining unit	T <sub>ps</sub>		Spearfish Formation
Minnekahta aquifer	P <sub>mk</sub>		Minnekahta Limestone
Opeche confining unit	P <sub>o</sub>		Opeche Shale
Minnelusa aquifer	P <sub>pm</sub>		Minnelusa Formation
Madison aquifer	M <sub>dm</sub>		Madison (Pahasapa) Limestone and Englewood Formation
Ordovician-sequence semiconfining unit	O <sub>u</sub>		Whitewood Formation and Winnipeg Formation
Deadwood aquifer	O <sub>ed</sub>		Deadwood Formation
Precambrian aquifer	p <sub>cu</sub>		Undifferentiated igneous and metamorphic rocks

- FAULT—Dashed where approximated. Bar and ball on down-thrown side
- ANTICLINE—Showing trace of axial plane and direction of plunge. Dashed where approximated
- SYNCLINE—Showing trace of axial plane and direction of plunge. Dashed where approximated
- MONOCLINE—Showing trace of axial plane. Dashed where approximated
- + DOME—Symbol size approximately proportional to size of dome. Dome asymmetry indicated by arrow length

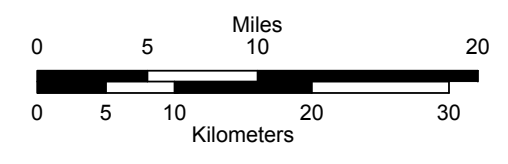

Base modified from U.S. Geological Survey digital data, 1:100,000, 1977, 1979, 1981, 1983, 1985  
Rapid City, Office of City Engineer map, 1:18,000, 1996; Universal Transverse Mercator projection, zone 13

Source: Carter et al. (2003)

**Figure 3-1**

**Geologic Map of the Black Hills**

**Dewey-Burdock Project**

DRAWN BY	Bonner, Hetrick
DATE	29-May-2012
FILENAME	BlackHillsGeoMap.dwg

**POWERTECH (USA) INC.**

sequence, which grades upward into marginal marine sediments where the Cretaceous Seaway inundated a stable land surface. Basal units of the Lakota Formation scour into clays of the underlying Morrison Formation and display the depositional nature of a large braided stream system crossing a broad, flat coastal plain and flowing toward the northwest. Younger fluvial sand units of the Lakota become progressively thinner and less continuous and are separated by thin deposits of overbank and flood plain silts and clays. At the top of the Lakota is the Fuson Member. The Fuson consists of shale with minor beds of fine grained sandstone and siltstone. The Fuson separates the underlying Lakota Formation from the overlying Fall River Formation. The Fall River consists of thick, widespread fluvial sands in the lower portion, grading to thinner, less continuous, marginal sands in the upper part. The Cretaceous Lakota and Fall River Formations are the hosts of the roll front uranium mineralization in the Black Hills region.

Following deposition of the Fall River, the region was covered by the North American Cretaceous Seaway, which resulted in the accumulation of vast thicknesses of marine sediments (from 3,000-5,000 feet thick). These marine sediments are represented by the Skull Creek Shale, Newcastle Sandstone, Mowry Shale, Belle Fourche Shale, Greenhorn Formation, Carlile Shale, Niobrara Formation and Pierre Shale. In Late Cretaceous time, the modern Rocky Mountain Uplift began, forcing the retreat of the Cretaceous seaway.

Unconformably overlying the Cretaceous sediments in the Black Hills region is the Tertiary-age (Oligocene) tuffaceous White River Formation. This thick, tuffaceous sequence was the result of volcanic eruptions to the west and is rich in volcanic fragments. The White River sediments have primarily been removed by erosion and can be found only as erosional remnants. This unit is thought to be the source of the uranium deposits found in the Black Hills region and the Powder River Basin of Wyoming.

The most recent sediments in the region are Quaternary-age deposits consisting of local material derived as a result of post-Laramide-uplift erosion. Recent deposits include alluvium and floodplain terrace deposits.

Refer to Figure 3-2 for a stratigraphic column of the Black Hills.

### ***3.1.2 Site Geology***

The site surface geology is shown in Figure 3-3. The Fall River Formation crops out across the eastern part of the project area and the Skull Creek Shale, Mowry Shale, and Belle Fourche Shale (collectively referred to as the Graneros Group) crop out across the western part of the project area. The formations dip west and southwest at 2 to 6 degrees.

Source: Driscoll et al. (2002)  
 § Modified based on drill-hole data

ERATHEM	SYSTEM	ABBREVIATION FOR STRATIGRAPHIC INTERVAL	STRATIGRAPHIC UNIT	THICKNESS IN FEET	DESCRIPTION		
CENOZOIC	QUATERNARY & TERTIARY (?)	QTac	UNDIFFERENTIATED ALLUVIUM AND COLLUVIUM	0 - 50	Sand, gravel, boulder and clay.		
		Tw	WHITE RIVER GROUP	0 - 300	Light colored clays with sandstone channel fillings and local limestone lenses.		
	TERTIARY	Tui	INTRUSIVE IGNEOUS ROCKS	--	Included rhyolite, latite, trachyte and phonolite.		
MESOZOIC	CRETACEOUS	Kps	PIERRE SHALE	1,200 - 2,700	Principal horizon of limestone lenses giving teepee buttes. Dark-gray shale containing scattered concretions. Widely scattered limestone masses giving small teepee buttes. Black fissile shale with concretions.		
			NIOBRARA FORMATION	80 - 300 §	Impure chalk and calcareous shale.		
			CARLILE SHALE	Turner Sandy Member Wall Creek Member	350 - 750 §	Light-gray shale with numerous large concretions and sandy layers. Dark-gray shale.	
			GREENHORN FORMATION	225 - 380	Impure slabby limestone. Weathers buff. Dark-gray calcareous shale with thin Oman Lake limestone at base.		
			GRANEROS GROUP	BELLE FOURCHE SHALE	150 - 850	Gray shale with scattered limestone concretions. Clay spur bentonite at base.	
				MOWRY SHALE	125 - 230	Light-gray siliceous shale. Fish scales and thin layers of bentonite.	
				MUDDY SANDSTONE	NEWCASTLE SANDSTONE	0 - 150	Brown to light-yellow and white sandstone.
				SKULL CREEK SHALE	150 - 270	Dark-gray to black siliceous shale.	
			Kik	INVAN KARA GROUP	FALL RIVER FORMATION	10 - 200	Massive to thin-bedded, brown to reddish-brown sandstone.
					LAKOTA FORMATION	Fuson Shale Minnewaste Limestone Chilson Member	10 - 190 0 - 25 25 - 485
	MORRISON FORMATION	0 - 220			Green to maroon shale. Thin sandstone.		
	JURASSIC	Ju	UNKPAPA SANDSTONE	0 - 225	Massive fine-grained sandstone.		
			SUNDANCE FORMATION	Redwater Member Lak Member Hulett Member Stockade Beaver Member Canyon Spr Member	250 - 450	Greenish-gray shale, thin limestone lenses. Glauconitic sandstone, red sandstone near middle.	
			GYPSUM SPRING FORMATION	0 - 45	Red siltstone, gypsum and limestone.		
			TRIASSIC	TRPs	SPEARFISH FORMATION Goose Egg Equivalent	375 - 800	Red silty shale, soft red sandstone and siltstone with gypsum and thin limestone layers. Gypsum locally near the base.
PALEOZOIC			PERMIAN	Pmk	MINNEKAHTA Limestone	25 - 65 §	Thin to medium-bedded, fine-grained, purplish gray laminated limestone.
	Po	OPECHE SHALE		25 - 150 §	Red shale and sandstone.		
	PPm	MINNELUSA FORMATION		375 - 1,175 §	Yellow to red cross-bedded sandstone, limestone and anhydrite locally at top. Interbedded sandstone, limestone, dolomite, shale and anhydrite. Red shale with interbedded limestone and sandstone at base.		
	MISSISSIPPIAN	MDme	MADISON (PAHASAPA) LIMESTONE	< 200 - 1,000 §	Massive light-colored limestone. Dolomite in part. Cavernous in upper part.		
	DEVONIAN		ENGLEWOOD FORMATION	30 - 60	Pink to buff limestone. Shale locally at base.		
	ORDOVIOAN	Ou	WHITEWOOD (RED RIVER) FORMATION	0 - 235 §	Buff dolomite and limestone.		
			WINNIPEG FORMATION	0 - 150 §	Green shale with siltstone.		
	CAMBRIAN	OEd	DEADWOOD FORMATION	0 - 500 §	Massive to thin-bedded buff to purple sandstone. Greenish glauconitic shale flaggy dolomite and flat-pebble limestone conglomerate. Sandstone with conglomerate locally at the base.		
	PRECAMBRIAN		pEu	UNDIFFERENTIATED IGNEOUS AND METAMORPHIC ROCKS		Schist, slate, quartzite and arkosic grit. Intruded by diorite, metamorphosed to amphibolite, and by granite and pegmatite.	

**Figure 3-2**

Stratigraphic Column of the Black Hills Area

Dewey-Burdock Project

DRAWN BY	Mays, Hetrick
DATE	29-May-2012
FILENAME	StratColBlackHills.dwg



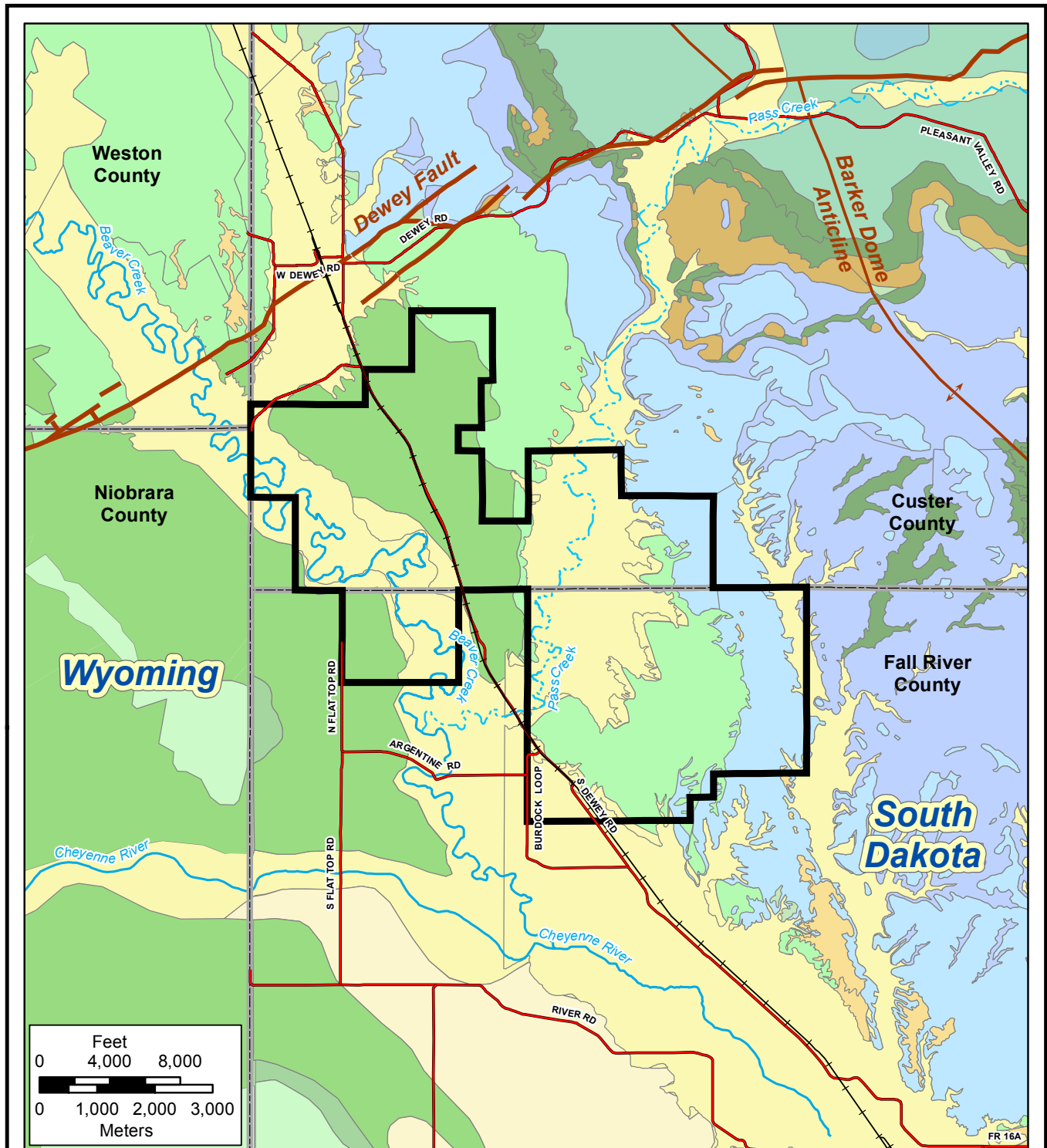

- Alluvium
- Gravel Deposits
- Landslide Deposits
- Carlile Shale
- Greenhorn
- Belle Fourche Shale
- Mowry and Skull Creek Shale
- Fall River
- Lakota
- Morrison, Sundance
- Spearfish

**Legend**

- Project Boundary
- County Roads
- BNSF Railroad
- Ephemeral Streams
- Perennial Streams
- Fault
- ↗↘ Anticline



**Figure 3-3**

Site Surface Geology

Dewey-Burdock Project

DRAWN BY	RESPEC, Hetrick
DATE	29-May-2012
FILENAME	SurfaceGeology.mxd



**POWERTECH (USA) INC.**

The geology of the project area was developed through the interpretation of data gathered from thousands of exploration drill holes. For each drill hole a suite of down-hole electric logs was run to characterize natural radioactivity and the lithology (rock type) of the sediments in the subsurface. Resistivity and self potential define the rock types encountered in the subsurface (sandstone, siltstone, shale, etc.). Figure 3-4 is an example of a “type log” from the project area. The electric logs were supported by a geologist’s description of the drill cuttings.

### **3.1.2.1 Site Structure**

The structure across the project area is simple and shows sediments dipping gently 2 to 6 degrees to the southwest. This is illustrated by structure contour maps on the tops of the Chilson Member of the Lakota Formation (Plate 3-1), the Fuson Shale (Plate 3-2), and the Fall River Formation (Plate 3-3). Isopach maps are also provided for the Chilson Member (Plate 3-4), Fuson Shale (Plate 3-5), and Fall River Formation (Plate 3-6).

The Dewey Fault, a northeast to southwest trending fault zone, is present approximately one mile north of the project area. The Dewey Fault is a steeply dipping to vertical normal fault with the north side uplifted by a combination of displacement and drag. In the project vicinity, the displacement is approximately 200 feet according to Brobst (1961) and exploration borehole data evaluated by Powertech (USA). The USGS considers an area 7 miles southeast of the project area as the Long Mountain Structural Zone. This northeast-southwest trend contains several small, shallow surface faults in the Inyan Kara. Despite the presence of faulting north and south of the site, there are no identified faults within the project area.

There is some folding in the areas surrounding the project area. East of the project area is a northwest-southeast trending anticline that ends in a closed structure called the Barker Dome. To the west is the Fanny Peak Monocline. This monocline is the structural boundary between the Black Hills and the Powder River Basin.

### **3.1.2.2 Site Stratigraphy**

The sedimentary rocks of primary interest that underlie the project area range in age from Upper Jurassic to Early Cretaceous. The Upper Jurassic Morrison Formation is considered to be the lowermost confining unit for the project, meaning that all ISR activities will be conducted above the Morrison Formation. The uranium mineralization is contained within the Inyan Kara Group (specifically within the Fall River Formation and Chilson Member of the Lakota Formation). The Graneros Group is the uppermost confining unit. Figure 3-4 illustrates the relationship



# PR-7

Elev. 3655

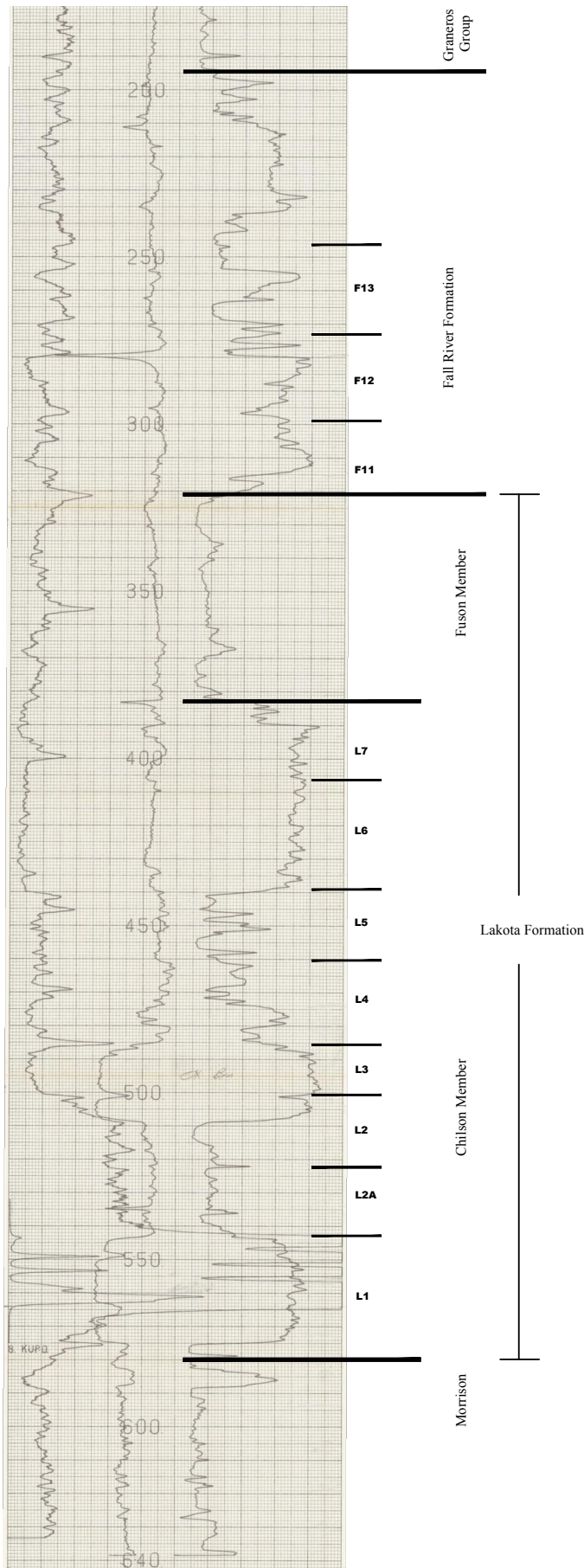

**Figure 3-4**  
Type Log

Dewey-Burdock Project

DRAWN BY	R. Lichnovsky	 <b>POWERTech (USA) INC.</b>
DATE	29-May-2012	
FILENAME	TypTypeLog.dwg	

between these sedimentary units. Figure 3-2 demonstrates the relationship between these sedimentary units and underlying rocks, ranging in age from Jurassic to Precambrian.

Plate 3-7 is a cross section spanning the project area. In addition to showing the scaled vertical location of each ore body proposed for uranium recovery, the cross section also illustrates the continuity of the Graneros Group, the Fuson Shale and the Morrison Formation, the major confining units, across the entire project area:

- 1) The Graneros Group is the uppermost confining unit and overlies the Fall River Formation. This marine shale sequence has a maximum thickness of 550 feet in the project area. The Graneros Group is composed of several geologic formations including the Skull Creek, Newcastle (not present in the project area), Mowry and Belle Fourche.
- 2) The Fuson Shale is the confining unit between the Fall River Formation and the Chilson Member of the Lakota Formation. The Fuson Shale is a low-permeability shale unit within the Fuson Member that ranges in thickness from 20 to 80 feet across the entire project area and crops out east of the project boundary.
- 3) The Morrison Formation is the lowermost confining unit and underlies the Chilson Member of the Lakota Formation. This low-permeability shale unit that ranges in thickness from 60 to 140 feet across the entire project area crops out east of the project boundary.

The focus of this report is the characterization of the Inyan Kara Group and analyses of potential impacts to the Inyan Kara aquifer from pumping at the Dewey-Burdock Project. Therefore, the following discussion is limited to the Inyan Kara Group. Additional information about regional and local geology and stratigraphy is available in Powertech (USA)'s NRC application for a source and byproduct material license for the Dewey-Burdock Project (Powertech, 2009).

**Inyan Kara Group** - This Group consists of the Lakota Formation and the Fall River Formation. Sandstones within these two formations are hosts to all the uranium mineralization for the project.

**Lakota Formation** - The Lakota Formation consists of three members: from lower to upper they are the Chilson Member, the Minnewaste Limestone Member and the Fuson Member.

The Chilson Member (commonly referred to as the Lakota Sandstone) is composed largely of fluvial deposits. These deposits consist of sandstone, shale, and siltstone. The member consists of a complex of channel sandstone deposits and their fine-grained lateral equivalents. The Chilson Member consists of two units: a basal carbonaceous black mudstone and an overlying unit of channel sandstones with fine-grained lateral equivalents and interbedded shales. The

sandstones are very fine to medium-grained and well sorted and were deposited by a northwest-flowing river system. Analyses of core samples of these sandstones indicate these units exhibit high horizontal permeabilities, ranging from  $2.6 \times 10^{-3}$  cm/sec to  $4.1 \times 10^{-3}$  cm/sec (2697 millidarcies to 4161 millidarcies). The massive sandstone is made up of numerous individual sand-filled channels, which contain the uranium deposits.

The isopach map of the Chilson Member of the Lakota Formation (Plate 3-4) shows the thickness of the channel sandstones and interbedded shales within the Chilson Member. Thicknesses vary from 100 to 240 feet. This isopach map may not adequately show the total thickness of the Chilson Member because drilling usually did not penetrate its entire extent. Drilling was usually stopped in the lower carbonaceous shale unit of the Chilson Member and did not reach the Morrison Formation.

The Minnewaste Limestone Member, although present in the region, is not present in the project area. Darton (1909) noted that the Minnewaste Limestone is some 20 feet thick at its type locality at the falls of the Cheyenne River (25 miles east of the project area, now under Angostura Reservoir). In USGS Professional Paper 763 (Gott et al., 1974), the Minnewaste Limestone is described in the type locality as being a pure limestone, but grading out laterally to a sandy limestone and to a calcareous sandstone at its margins. Gott et al. also state that it is discontinuous west and northwest of the type locality (toward the Dewey-Burdock project area).

A review of all drill hole and geologic lithology logs confirms the Minnewaste Limestone does not occur within the project area. If present, this limestone unit would occur immediately beneath the Fuson Shale confining unit and above the Chilson Member of the Lakota Formation. A limestone would have a characteristically high (off-scale) response on the resistivity curve on the electric logs.

The Fuson Member is the uppermost member of the Lakota Formation. The shale-siltstone portion of the Fuson (Fuson Shale) separates the Chilson Member of the Lakota Formation from the Fall River Formation.

The Fuson Shale is differentiated from the Fuson Member of the Lakota Formation by Powertech (USA) for the purpose of characterizing the site geology. The Fuson Shale has been mapped by Powertech (USA) based on borehole logs and geophysical logs for exploratory holes and consists of 20 to 80 feet of low-permeability shales and clays, which generally occur at or near the base of the unit. The Fuson Member of the Lakota, in comparison, has been mapped by the USGS and others to be from 40 to 80 feet thick and consisting of interbedded fluvial shales, clays, mudstones, and sands.

The Fuson Member is described as having a lower discontinuous sandstone unit at its base and an upper discontinuous sandstone at the top of the member. If present the lower sandstone unit was mapped as Chilson sandstone. Similarly if the upper sandstone was present it was mapped as Fall River sandstone. The isopach map of the Fuson Shale shows the thickness of the shale – siltstone unit ranging from 20 to 80 feet (Plate 3-5). It shows thinning of the shale under the overlying channel sandstones of the Fall River Formation.

The shales and mudstones within the Fuson Shale are highly stratified and anisotropic. Due to the highly stratified nature of the interbedded shales and mudstones, the vertical permeability is estimated to be several orders of magnitude smaller than the horizontal permeability. Estimates of vertical hydraulic conductivity of the Fuson Shale developed from pumping tests conducted in the Fall River and Chilson near Burdock in 1979 range from  $1 \times 10^{-7}$  to  $4.6 \times 10^{-8}$  cm/s (Boggs and Jenkins, 1980). Further, analyses of core samples of these lithologies demonstrate low vertical permeabilities, ranging from  $7.8 \times 10^{-9}$  cm/sec to  $2.2 \times 10^{-7}$  cm/sec (0.008 millidarcies to 0.228 millidarcies). Detailed pump tests to be conducted after NRC license issuance as a part of the well field hydrogeologic packages will provide additional quantification of the low hydraulic conductivity of the confining units.

The Fuson Member, being of fluvial origin, contains sand deposits (Schnabel and Charlesworth, 1963). The presence of the sand facies within the Fuson Member does not diminish the confining capacity of the Fuson Shale within the Fuson Member as defined and mapped by Powertech (USA). The geologic map of the Burdock quadrangle (Schnabel and Charlesworth, 1963) indicates that the Fuson Shale may pinch out in some areas. In particular, the interpretive fence diagram presented by Schnabel and Charlesworth shows an area approximately 1½ miles east and northeast of the project area, across Bennett Canyon, in the E/2 Section 30, T6S, R2E, where the Fuson Member pinches out. However, based on Powertech (USA)'s borehole logs there is no evidence of the Fuson Shale pinching out within the project area.

The Fuson Shale is continuous and no less than 20 feet thick throughout the entire project area. The pervasive occurrence and continuity of the Fuson Shale throughout the project area is shown on the geologic cross section (Plate 3-7).

**Fall River Formation** - The Fall River Formation is composed of carbonaceous interbedded siltstone and sandstone, channel sandstones, and a sequence of interbedded sandstone and shale. The lower part of the Fall River consists of dark carbonaceous siltstone interbedded with thin laminations of fine-grained sandstone. Channels were cut into this interbedded sequence by northwest flowing rivers, and fluvial sandstones were deposited. These channel sandstones occur

across various parts of the project area and generally contain the uranium deposits. Overlying the channel sandstones is another sequence of alternating sandstones and shales. The sandstones are cross-bedded to massive, fine- to medium-grained, and well-sorted.

The isopach map of the Fall River Formation (Plate 3-6) shows a range of thickness of 120 to 160 feet. The thickening of the formation indicates the presence of channel sandstones. Along the northeastern portion of the project area, this formation is exposed on the surface and erosion has taken place.

## **3.2 Hydrogeology**

In this section, groundwater occurrence and flow are described specifically as they relate to the Dewey-Burdock Project and the Inyan Kara water right permit application. While the project area is generally similar to the Black Hills regional setting, the site hydrogeology has several unique characteristics as described below.

### ***3.2.1 Regional Hydrogeology***

The Black Hills Uplift is the principal recharge area for the regional bedrock aquifer systems in southwestern South Dakota and northeastern Wyoming. The stratigraphy of the Black Hills area is summarized on Figure 3-2. Regionally, four principal aquifers are utilized as major sources of water supply. These are the Inyan Kara Group, Minnelusa Formation, Madison Limestone, and Deadwood Formation. In addition to these four major aquifers, other units including the Precambrian, Minnekahta Limestone, Sundance Formation, and Unkpapa Sandstone are utilized locally as sources of water supply at or near the outcrop areas in the central portion of the Black Hills. Figure 3-5 presents a simplified view of the hydrogeologic setting of the Black Hills. Within the project area, none of the deeper regional aquifers below the Sundance Formation is used as a water supply, mainly because of the availability of shallower sources and/or the poor water quality in the deeper aquifers. There are no water supply wells within 1.2 miles of the project area completed in aquifers below the Sundance Formation. The closest municipal wells are the Edgemont Madison wells, which are approximately 15 miles to the south-southeast of the center of the project area.

In the 1990s, the USGS undertook an extensive study focusing on the evaluation of the hydrologic significance of selected bedrock aquifers in the Black Hills area – specifically the Deadwood, Madison Limestone, Minnelusa, Minnekahta, and Inyan Kara aquifers. In these

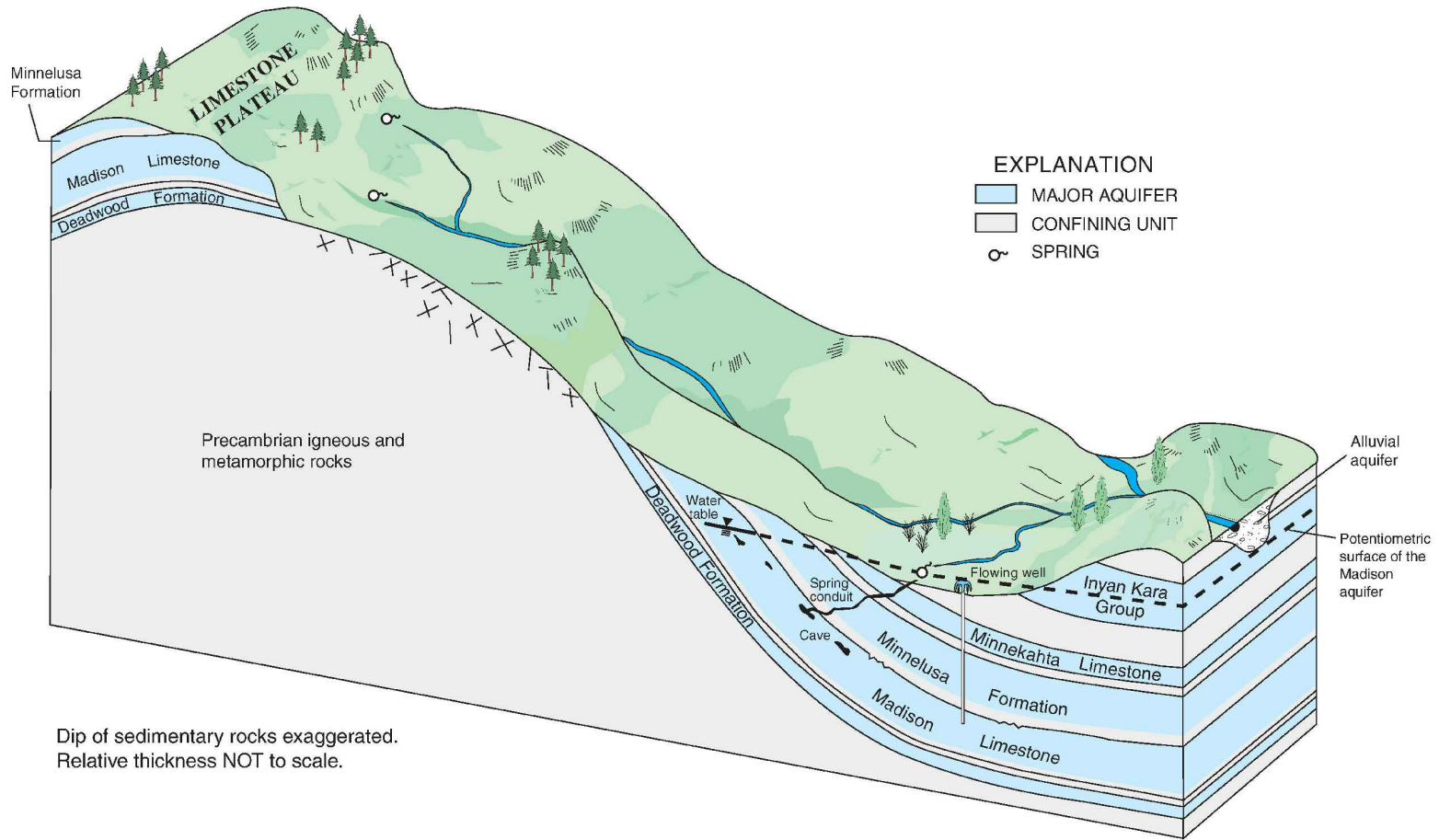

**Figure 3-5**  
 Diagram Showing a Simplified  
 View of the Hydrogeologic  
 Setting of the Black Hills Area

Dewey-Burdock Project

DRAWN BY	Mays, Hetrick	 <b>POWERTECH (USA) INC.</b>
DATE	29-May-2012	
FILENAME	Driscoll_L.dwg	

Source: Carter et al. (2003)

evaluations, the USGS placed priority on the Madison and Minnelusa aquifers, both of which are used extensively elsewhere in the region for water supplies.

While the review of regional hydrology is prudent and necessary for this application, the site hydrology within the project area has unique characteristics compared to the regional Black Hills hydrology. In this regard, intermediate groundwater flow systems in the Fall River Formation and the Chilson Member of the Lakota Formation are independent of the regional flow system. These intermediate flow systems have their origin in the areas within the eastern portion of the project area (Fall River) and immediately to the east and north of the project area (Fall River and Chilson) where the Fall River and Chilson crop out at the land surface. Both of these flow systems are recharged directly by precipitation and infiltration of surface runoff along the outcrops in the eastern portion and adjacent to the project area.

### **3.2.1.1 Inyan Kara Aquifer**

The focus of this report is the Inyan Kara aquifer. Information on other aquifers in and near the project area can be found in Powertech (USA)'s NRC license application (Powertech, 2009). In and near the project area, the Inyan Kara Group typically contains the first significant aquifer encountered. The Inyan Kara includes two sub-aquifers, the Chilson Member of the Lakota Formation and the Fall River Formation, which are separated by the Fuson Shale confining unit. The Inyan Kara aquifer is heterogeneous, which results in the two sub-aquifers exhibiting large variations in their hydraulic characteristics at some locations. Regionally, the Inyan Kara ranges from 250 to 500 feet thick, exhibits a large effective porosity (17 percent), and can yield considerable quantities of water from storage (Driscoll et al., 2002). Within the Black Hills, the transmissivity of the Inyan Kara ranges from 1 to 6,000 ft<sup>2</sup>/day. Table 3-1 summarizes the hydraulic properties of the Inyan Kara Aquifer determined in previous investigations. The Inyan Kara is confined below by the Jurassic Morrison Formation and above by the Cretaceous Graneros Group.

### **3.2.2 Site Hydrogeology**

The main aquifers to be utilized by the Dewey-Burdock Project (the Fall River and Chilson) are recharged locally and are isolated from the deep regional flow system in the Paleozoic formations that typically characterize regional groundwater flow and are the focus of numerous USGS research studies.

**Table 3-1: Summary of Hydraulic Properties of the Inyan Kara Aquifer**

Source	Hydraulic Conductivity (ft/d)	Transmissivity (ft <sup>2</sup> /d)	Storage Coefficient	Total Porosity/ Effective Porosity	Area Represented
Niven, 1967	0 – 100	--	--	--	Eastern Wyoming, western South Dakota
Miller and Rahn, 1974	0.944	178	--	--	Black Hills area
Gries and others, 1976	1.26	250 – 580	$2.1 \times 10^{-5} - 2.5 \times 10^{-5}$	--	Wall area, South Dakota
Boggs and Jenkins, 1980	--	50 – 190	$1.4 \times 10^{-5} - 1.0 \times 10^{-4}$	--	Northwestern Fall River County
Bredehoeff and others, 1983	8.3	--	$1.0 \times 10^{-5}$	--	South Dakota
Rahn, 1985	--	--	--	0.26/0.17	Western South Dakota
Kyllonen and Peter, 1987	--	0.86 – 6,000	--	--	Northern Black Hills

Source: Driscoll et al., 2002

In the project area, the sedimentary rocks dip gently to the southwest at 2 to 6 degrees. As the land surface is generally flatter than the dip of the underlying bedrock strata, younger strata crop out at the ground surface sequentially from east to west.

The structure is illustrated by the structural contour maps on top of the Chilson Member of the Lakota (Plate 3-1), Fuson Shale (Plate 3-2) and Fall River (Plate 3-3). As noted, based on the logs from thousands of exploration holes, no major faults or other structural features have been identified within the project area.

### **3.2.2.1 Site Hydrostratigraphic Units**

The Fall River and Chilson Member of the Lakota Formation are the principal sources of water in the vicinity of the project area for domestic, livestock, and agricultural uses. These same formations are the host rocks for the uranium mineralization within the project area. Within the project area, the deeper regional aquifers are not used as a source of water supply mainly because of their depth of occurrence, availability of shallower sources, relatively low productivity and low historical water demands. There are no water supply wells within 1.2 miles of the project area completed in aquifers below the Sundance Formation. The closest municipal wells are the Edgemont Madison wells, which are approximately 15 miles from the center of the project area. Refer to Section 3.1.2.2 for a description of the Inyan Kara Group stratigraphic units within the project area.

### **3.2.3 Groundwater Occurrence and Flow**

Potentiometric contour maps for the Fall River and the Chilson Member of the Lakota are shown on Figures 3-6 and 3-7, respectively. These maps were prepared using water level measurements



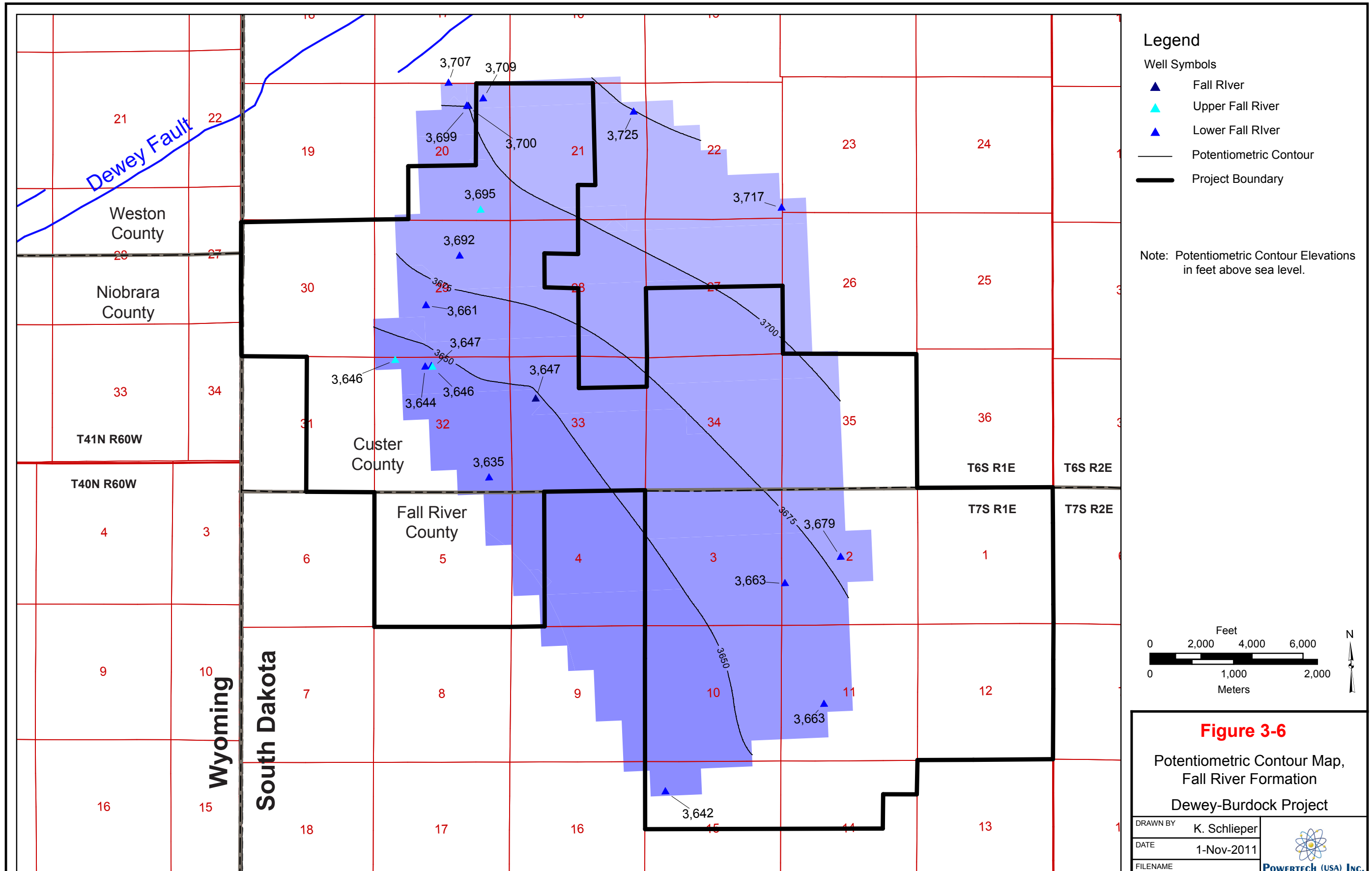

**Legend**

Well Symbols

- ▲ Fall River
- ▲ Upper Fall River
- ▲ Lower Fall River
- Potentiometric Contour
- ▬ Project Boundary

Note: Potentiometric Contour Elevations in feet above sea level.

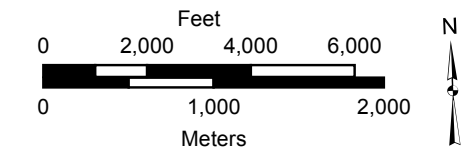

**Figure 3-6**

Potentiometric Contour Map,  
Fall River Formation  
Dewey-Burdock Project

DRAWN BY K. Schlieper

DATE 1-Nov-2011

FILENAME 2011\_DB\_Fig\_2.7-16a.ai



**POWERTECH (USA) INC.**

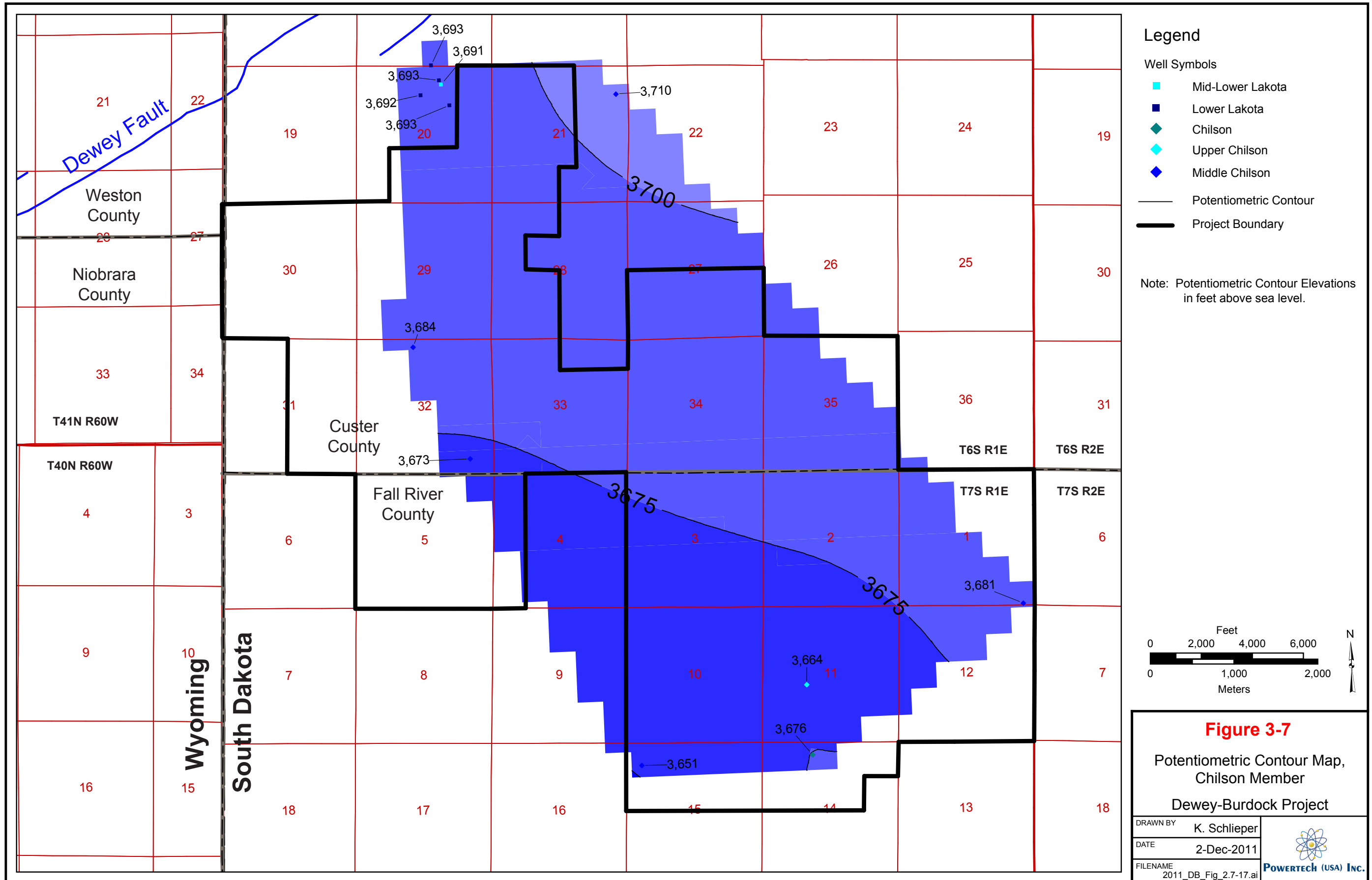

**Legend**

Well Symbols

- Mid-Lower Lakota
- Lower Lakota
- ◆ Chilson
- ◆ Upper Chilson
- ◆ Middle Chilson
- Potentiometric Contour
- Project Boundary

Note: Potentiometric Contour Elevations in feet above sea level.

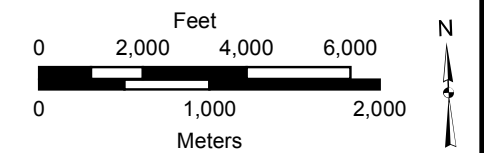

**Figure 3-7**

Potentiometric Contour Map,  
Chilson Member  
Dewey-Burdock Project

DRAWN BY	K. Schlieper
DATE	2-Dec-2011
FILENAME	2011_DB_Fig_2.7-17.ai



taken over a 5-day period from April 25 through April 29, 2011. The data used to generate Figures 3-6 and 3-7 are presented in Appendix A.

The potentiometric surface map for the Fall River (Figure 3-6) shows a relatively uniform hydraulic gradient across the project area, with the potentiometric levels decreasing to the southwest. The potentiometric surface for the Chilson (Figure 3-7) shows a slight flattening of the hydraulic gradient across the northwestern portion of the project area but with heads also decreasing to the southwest.

### **3.2.3.1 Groundwater Flow Systems**

Based on the regional and site-specific hydrogeological characterization, groundwater occurrence and flow in the project area can be subdivided into three main components, or flow regimes. These include the deep regional flow system, a shallow perched groundwater flow system, and an intermediate groundwater flow system that includes the Fall River and Chilson aquifers.

There are multiple deep regional groundwater flow systems within the Paleozoic section. These regional flow systems are associated with the permeable strata within the Deadwood, Madison, Minnelusa, Sundance, and minor aquifers such as the Unkpapa. These deep regional flow systems and associated aquifers are isolated by low-permeability layers, or confining beds, from the shallower formations that are the target of the proposed ISR operations in the Inyan Kara Group in the project area.

Shallow, perched groundwater systems exist within the alluvium associated with Beaver Creek, Pass Creek, and Bennett Canyon on the eastern edge of the project area. These alluvial systems are perched above the top of the Graneros on the western portion of the project area. Groundwater flow within the alluvium in most situations is generally parallel to surface drainage patterns. In the case of Bennett Canyon, the alluvium directly overlies the Chilson Member of the Lakota. As such, the alluvial groundwater is a potential source of recharge to the underlying Chilson.

Intermediate groundwater flow systems exist within the Fall River Formation and the Chilson Member of the Lakota. These intermediate flow systems have their origins in the areas within the eastern portion of the project area (Fall River) and immediately to the east and north of the project area where the Fall River and Chilson crop out at the land surface. Both of these flow systems are recharged directly by precipitation that falls on the land surface and by infiltration of

surface runoff, primarily in the Pass Creek and Bennett Canyon drainages north and east of the project area, respectively.

Within the project area, the Fall River and the Chilson dip gently to the southwest at 2 to 6 degrees away from their outcrop areas. As a result, groundwater flow within the Fall River and the Chilson generally occurs from the northeast to the southwest toward the Powder River Basin.

#### 3.2.3.1.1 Groundwater Recharge and Discharge

The hydrologic characterization for the project area included the measurement of water levels in wells completed in the Inyan Kara, overlying alluvium, and the underlying Unkpapa Sandstone. The current data collection programs began in 2007 and continued through 2011. The observed water levels are summarized in Appendix A.

The Pass Creek watershed north of the project area is a major source of recharge to both the Fall River and Chilson where they are exposed at the land surface or subcrop beneath the alluvium.

The Fall River Formation rises to the north and east and crops out at the ground surface. To the southwest the Fall River Formation dips at a steeper angle than the ground surface and is mantled by the overlying Graneros Group. The recharge areas for the Fall River and Lakota (Chilson) where these units are exposed at the ground surface or covered by alluvium are shown on Figure 3-8.

The recharge areas for the regional groundwater flow systems within the Minnelusa Formation, Madison Limestone, and Deadwood Formation are in their outcrop areas further to the northeast on the flanks of the Black Hills Dome. As a result of the rise in elevation, the older formations outcrop closer to the center of the dome at higher elevations and exhibit greater potentiometric elevations. Because of this, the potentiometric levels within the geologic section increase with depth, as noted previously.

#### 3.2.3.1.2 Hydraulic Isolation of Aquifers

Regionally, the Inyan Kara Group is geologically confined. At the project site, the Graneros Group shale serves as the overlying confining unit above the Fall River in the western portion of the site. There are no major aquifers above the Inyan Kara. Below the Inyan Kara, the Morrison Formation serves as a confining unit. At the project site, results from recent pump tests show that the Morrison effectively confines the underlying Unkpapa Sandstone since no measureable drawdown in the Unkpapa was observed while pumping in the Inyan Kara.

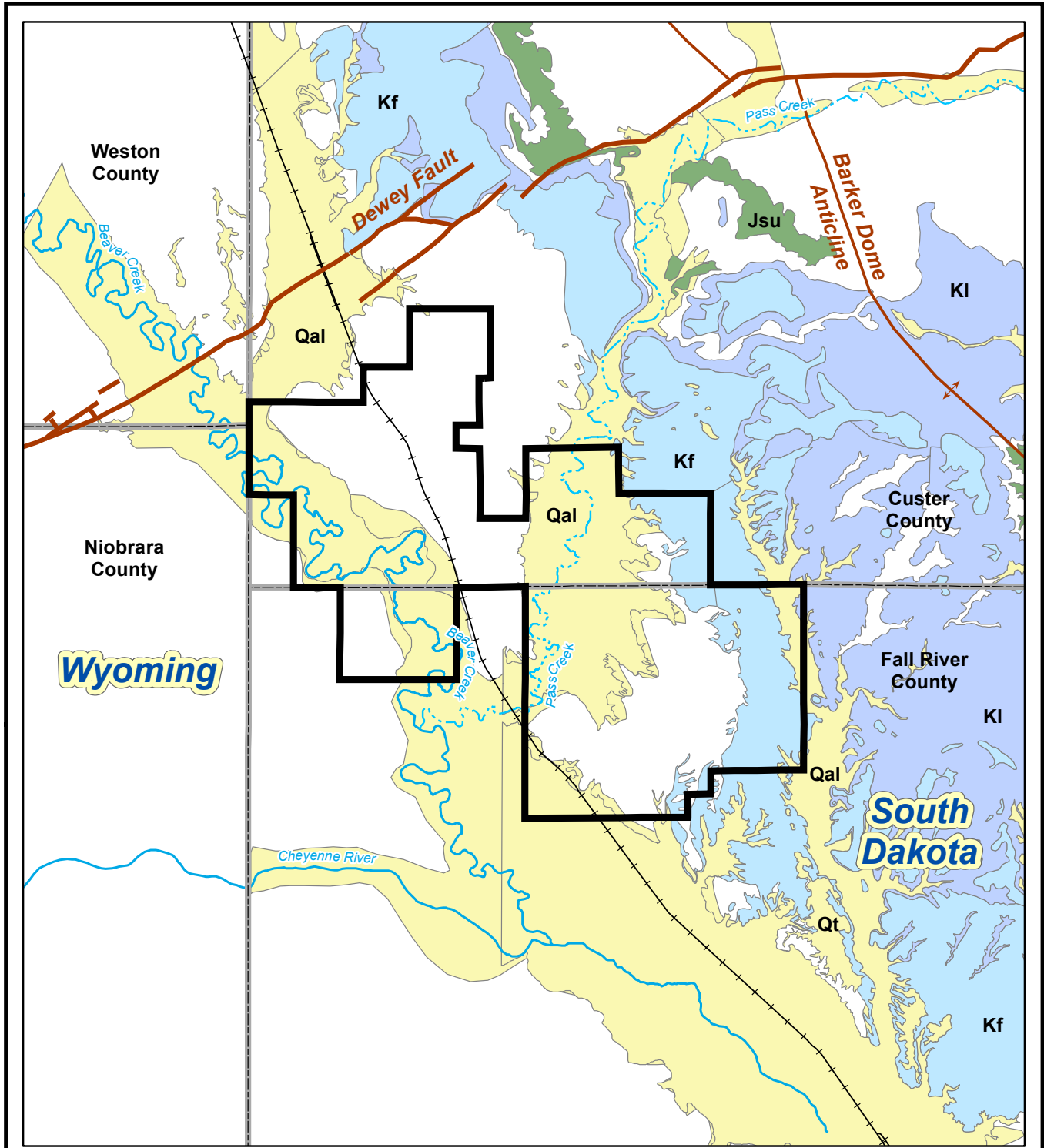

**Legend**

- Project Boundary
- BNSF Railroad
- Ephemeral Streams
- Perennial Streams
- Fault
- Anticline
- Overlying Alluvium and Gravel, Qal and Qt
- Fall River, Kf
- Lakota, KI
- Sundance/Unkpapa, Jsu

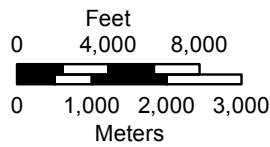

**Figure 3-8**

Recharge Areas for the  
Fall River and Lakota Formations

Dewey-Burdock Project

DRAWN BY	RESPEC, Hetrick
DATE	29-May-2012
FILENAME	RechargeAreas.mxd



Based on borehole logs and geophysical logs for exploration holes, the Fuson Shale is continuous and no less than 20 feet thick throughout the entire project area. An isopach map showing the thickness and continuity of the Fuson Shale throughout the project area is presented as Plate 3-5. The pervasive occurrence and continuity of the Fuson Shale throughout the project area are shown on the geologic cross section (Plate 3-7).

### 3.2.3.1.3 Groundwater Use

The major aquifers in the Black Hills include the Precambrian, Deadwood, Madison, Minnelusa, and Inyan Kara. Each of these aquifers is used to varying degrees, depending on location, depth of occurrence and location related to population. The estimated groundwater use in Custer and Fall River counties is summarized in Table 3-2.

**Table 3-2: Estimated Groundwater Use in Custer and Fall River Counties, South Dakota**

Water Use Type	Withdrawals (MGD)	
	<i>Custer County</i>	<i>Fall River County</i>
Public Supply GW	0.48	1.32
Domestic GW	0.34	0.16
Irrigation GW	0.09	0.13
Livestock GW	0.12	0.25
Mining GW	0.00	0.03
Total GW	1.03	1.89

Source: Kenny et al., 2005

Notes: GW = Groundwater

MGD = Million gallons per day

Within the project area the Inyan Kara Group is the principal source of water for livestock, domestic use and other purposes.

Section 4.2.2 describes the inventory of wells within the project area and 1.2-mile (2 km) surrounding area.

## 4.0 POTENTIAL IMPACTS

According to DENR (2008), the following criteria must be met in order for DENR to grant a water rights permit:

- 1) Water must be available for the proposed use.
- 2) The proposed diversion can be developed without unlawful impairment of existing rights.
- 3) The use of water must be a beneficial use.
- 4) The use of water must be in the public interest.

The following sections demonstrate that sufficient water is available in the Inyan Kara aquifer for the proposed use (criterion #1) and the proposed diversion can be developed without unlawfully impairing existing rights (criterion #2). Section 2.1 addresses beneficial use of water and public benefits, including job creation and significant state and local tax revenue.

### 4.1 Water Availability

DENR (2008) states that in order to approve a groundwater right, “the annual use from the water source may not exceed the average estimated annual recharge with some limited exceptions.” Recharge to the potentially affected portion of the Inyan Kara aquifer was estimated by varying recharge during calibration of the numerical groundwater model until steady-state calibration was achieved. Model results are provided in Appendix D. The numerical groundwater model achieved calibration at recharge rates of 136 gpm and 210 gpm, respectively, in the Fall River and Chilson aquifers. This totals 346 gpm or 558 ac-ft/yr. The maximum requested net Inyan Kara water usage of 274.2 ac-ft/yr (170 gpm) is therefore about 49 percent of the estimated annual recharge to the relatively small portion of the Inyan Kara aquifer potentially affected by this water right application.

### 4.2 Potential Impacts to Existing Water Rights and Domestic Wells

In the Summary of South Dakota Water Laws and Rules, DENR states that, “Existing rights, including domestic uses of water, may not be unlawfully impaired regardless of whether the proposed source is a surface or ground water” (DENR, 2008). The following sections present the inventory of existing Inyan Kara water rights and domestic wells in and around the project area and demonstrate that existing uses will not be impaired by the Dewey-Burdock Project.

#### 4.2.1 Existing Groundwater Rights

A map of groundwater rights within 1.2 miles (2 km) of the project area is presented in Figure 4-1. There are no groundwater rights within the project area and only two groundwater rights

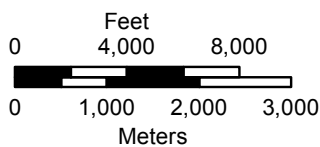
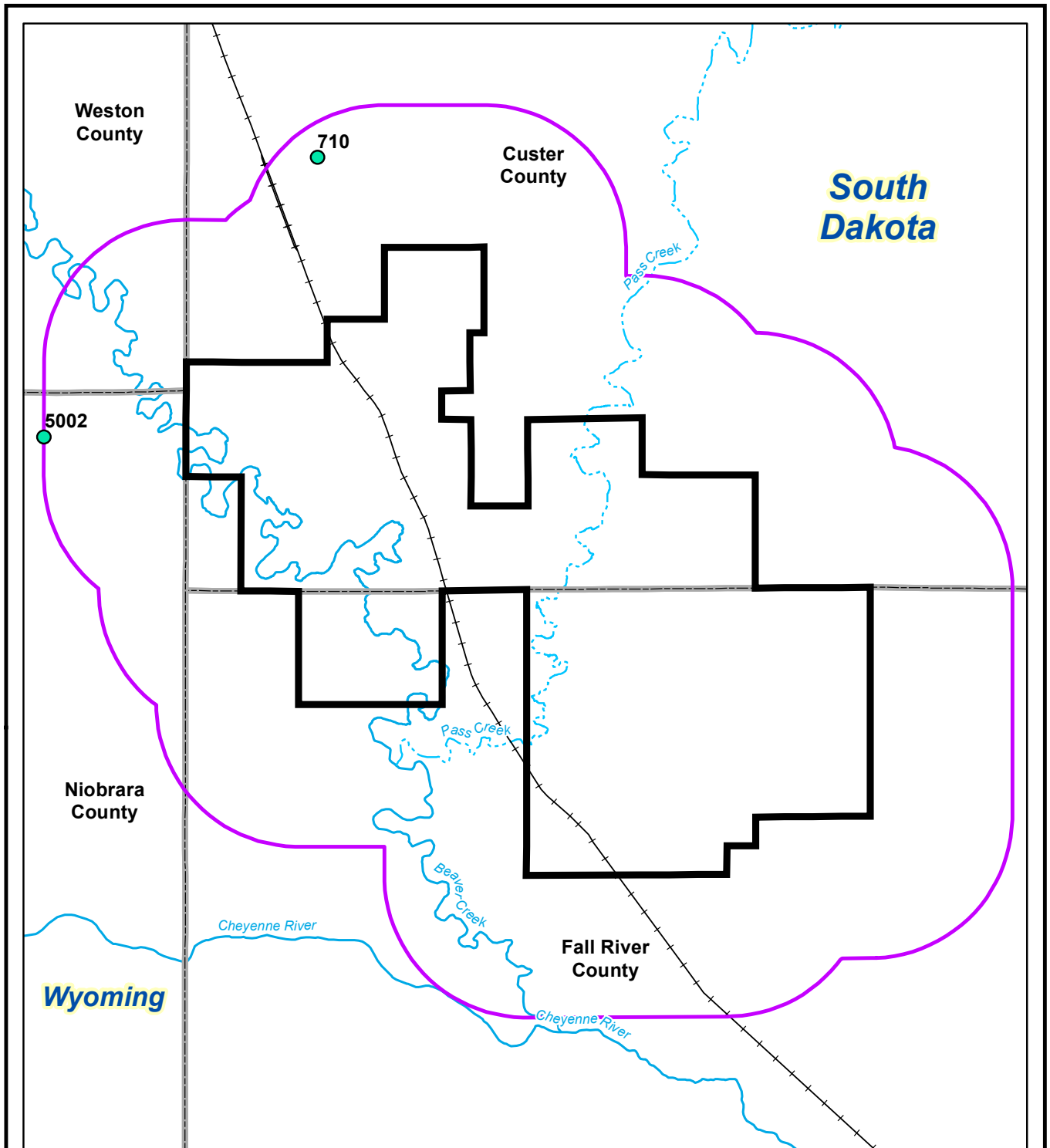

**Legend**

- Project Boundary
- 2 km from Project Boundary
- BNSF Railroad
- Ephemeral Streams
- Perennial Streams
- Groundwater Rights



**Figure 4-1**

Groundwater Rights within 2 km of the Dewey-Burdock Project Area

**Dewey-Burdock Project**

DRAWN BY	S. Hetrick
DATE	15-Mar-2012
FILENAME	H2ORights2km.mxd





**Table 4-1: Groundwater Rights within 2 km of the Dewey-Burdock Project Area**

Permit #	Location Information				Applicant/Facility Name	Use Type	Diversion Name/Source	Total Depth (ft)	Permitted Diversion Rate (cfs)	Priority Date
	Legal Location									
	T.	R.	Sec.	Qtr Qtr						
380-2	6S	1E	17	NWNW	H. Hollenbeck	IRR	Inyan Kara Aquifer	376	0.85	06/29/1951
P183561W	41N	60W	28	SWSW	Putnam & Putnam, LLP	STO	Unknown	639	0.011	06/12/2007

within 2 km of the project area, one in South Dakota and one in Wyoming (Table 4-1). The groundwater permit in South Dakota (No. 380-2) appropriates 0.85 cfs (381.5 gpm) from the Inyan Kara for irrigation use. The Wyoming groundwater water right (No. P183561W) is permitted for 5 gpm (0.011 cfs) for stock use. According to well records obtained from the Wyoming State Engineer's Office, the well was completed in 1936 to a depth of 639 feet. The production interval is listed as unknown. Based on the well depth, well location, extrapolation of geologic data provided in Section 2, and the fact that it is a flowing artesian well, Powertech (USA) assumes that this well is completed in the Inyan Kara.

Potential impacts to existing water rights will be minor as described in Sections 4.2.3 and 4.2.4.

#### **4.2.2 Well Inventory**

Historical records and field investigations conducted within 1.2 miles (2 km) of the project area were used to develop the well inventory. An initial investigation of the wells was completed in 2007, and additional surveys were conducted in 2011 to evaluate the use and condition of the wells. A total of 109 wells have been identified within 2 km of the project area. There are also 27 wells with historical records that are currently not present at the surface and 17 wells with historical records that have been visually confirmed as plugged and abandoned. Appendix B contains well inventory summary tables and Appendix C contains the detailed well inventory, well completion records and associated documentation. Plate 4-1 depicts existing wells within 2 km of the project area.

Table 1 in Appendix B summarizes the well inventory. Listed wells have one of the following uses:

- Domestic: Are currently used or can reasonably be expected to be used for drinking water use, including wells which are also used for livestock watering (18 wells)
- Stock: Watering of livestock is sole use; well cannot be used for drinking water use (i.e., no piping to domestic water system, etc.) (43 wells)
- Irrigation: Permitted to be used for irrigation (1 well)
- Monitor: Sole use is for monitoring (47 wells)

Table 2 in Appendix B lists the wells identified in historical records that were not evident at the surface during the field investigations. Several of these wells are suspected to be plugged and abandoned. Powertech (USA) will continue to search for these wells. During design of well

fields, pump testing will be designed to locate any such wells and to detect any potential impacts from such wells on the ISR operations.

Table 3 in Appendix B lists all of the wells within the inventory area that have been confirmed by Powertech (USA) to have been plugged and abandoned. Each well was visually inspected, and it has been determined that cement was placed within the well bores.

#### ***4.2.3 Potential Drawdown Impacts***

Petrotek Engineering Corporation (Petrotek) prepared a numerical groundwater flow model using site-specific data to predict hydraulic responses of the Fall River and Chilson aquifers to ISR production and restoration operations at the Dewey-Burdock Project. A primary model objective was to predict drawdown on a local and regional scale.

The numerical groundwater model domain encompasses nearly 360 square miles with north-south and east-west dimensions of 100,000 ft (18.9 miles). The northern and eastern boundaries of the model domain represent the updip limits of saturated conditions within the Inyan Kara aquifer system. The southern and western boundaries of the model extend at least 10 miles beyond the project area. The Dewey Fault forms a no-flow boundary along the northwestern and northern boundaries of the model domain. Four layers were modeled. From shallowest to deepest these include the Graneros Group, Fall River Formation, Fuson Shale, and the Chilson Member of the Lakota Formation.

The model was calibrated to average 2010-2011 water level data by varying recharge to the Fall River and Chilson aquifers. Transient calibrations were also performed by simulating results of the 2008 aquifer tests conducted in support of the NRC license application. The calibrated model was then verified through simulation of aquifer tests conducted in 1982 by TVA.

Operational simulations were performed for gross Inyan Kara production rates ranging from 4,000 to 8,000 gpm. Restoration was simulated as a 1% bleed for a 500 gpm, gross restoration flow rate (5 gpm net extraction). Additional restoration bleed was also simulated for the groundwater sweep option. Figures 4-2 and 4-3 depict the modeled maximum drawdown for the Fall River and Chilson, respectively, at an 8,000 gpm gross production rate with a 1% production bleed and 1% aquifer restoration bleed applied to a 500 gpm gross restoration rate plus groundwater sweep. This represents a maximum net Inyan Kara water usage rate of 147.2 gpm, or about 87% of the maximum rate proposed in the two Inyan Kara water rights applications. Complete model results are provided in Appendix D.

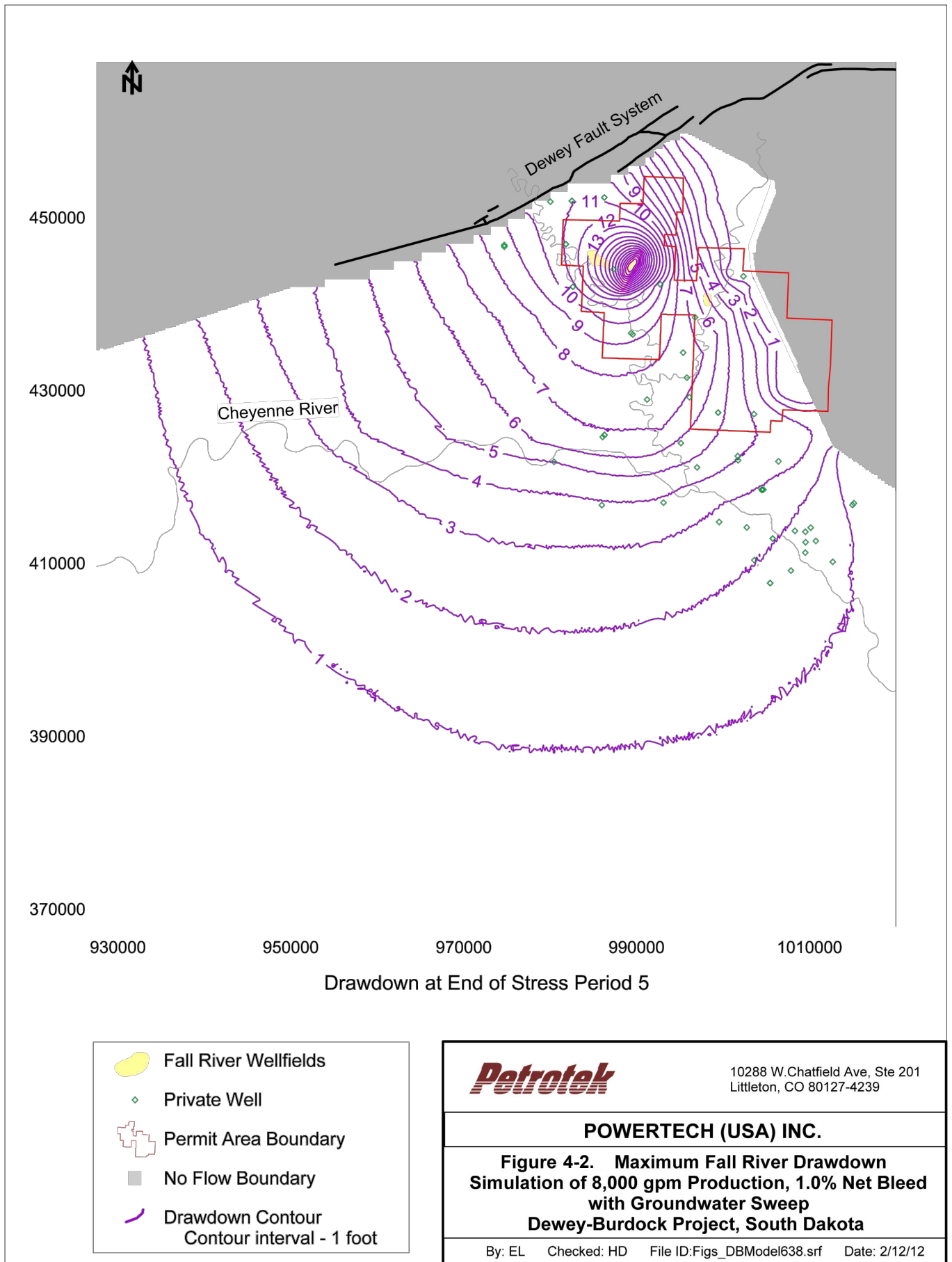

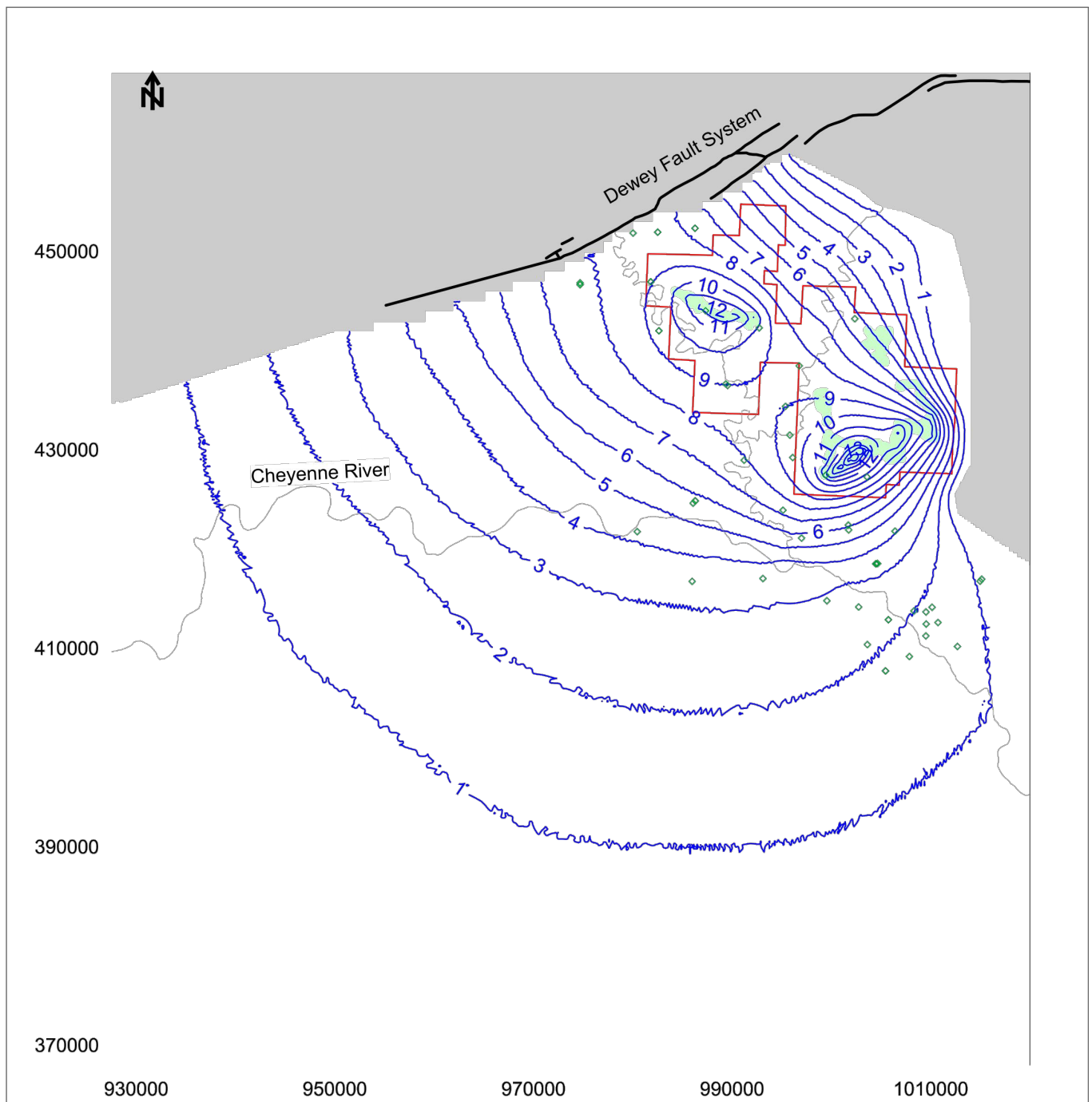

Drawdown at End of Stress Period 8

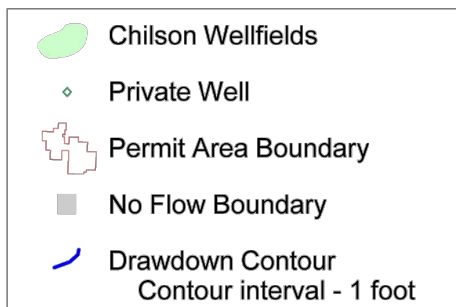

<b><i>Petrotek</i></b>	10288 W. Chatfield Ave, Ste 201 Littleton, CO 80127-4239
<b>POWERTECH (USA) INC.</b>	
<b>Figure 4-3. Maximum Chilson Drawdown Simulation of 8,000 gpm Production, 1.0% Net Bleed with Groundwater Sweep Dewey-Burdock Project, South Dakota</b>	
By: EL    Checked: HD    File ID: Fig_DBModel639.srf    Date: 2/12/12	

Figure 4-2 shows the maximum predicted drawdown in the Fall River Formation, and Figure 4-3 shows the maximum predicted drawdown in the Chilson. Maximum drawdown outside the project area during the simulation was slightly more than 12 feet within the Fall River and approximately 10 feet in the Chilson. The groundwater model report in Appendix D shows that potential drawdown impacts will be short-lived, with recovery to within 1 to 2 feet of pre-ISR levels within one year after the end of ISR operations.

#### ***4.2.4 Potential to Unlawfully Impair Existing Water Rights or Domestic Wells***

Powertech (USA) will not unlawfully impair existing water rights. As described in Section 4.2.1, there are only two existing Inyan Kara water rights within 1.2 miles (2 km) of the project area, one in South Dakota and one in Wyoming. According to USGS mapping (Brobst, 1961), the nearest South Dakota water right (380-2) is approximately 1.0 mile (1.6 km) away and across the Dewey Fault. In this vicinity the fault offsets the Inyan Kara aquifer by about 200 feet according to Brobst (1961) and exploration borehole data evaluated by Powertech (USA). This offset is assumed to prevent flow across the fault in either the Fall River or Chilson aquifers (refer to Appendix D). Therefore, there is no potential to unlawfully impair this existing Inyan Kara water right.

The nearest Wyoming water right (P183561W) is approximately 1.2 miles (2.0 km) west of the project area. The maximum predicted Inyan Kara aquifer drawdown in this vicinity is approximately 8 to 9 feet (Figures 4-2 and 4-3). Directly west of the project area the Fall River and Chilson are both hydraulically confined, with artesian pressure frequently sufficient to yield flowing artesian wells, including P183561W. The potential to impair this existing water right is very limited by the small drawdowns caused by the ISR operation, by artesian conditions and distance from the water right to the project area.

The monitoring and mitigation plan described in Section 5 will assure that domestic wells are not adversely impacted by the proposed diversions. As defined in ARSD 74:02:04:20(7), an adversely impacted domestic well is, “a well in which the pump intake was set at least 20 feet below the top of the aquifer at the time of construction or, if the aquifer is less than 20 feet thick, is as near to the bottom of the aquifer as is practical and the water level of the aquifer has declined to a level that the pump will no longer deliver sufficient water for the well owner’s needs.” Through existing lease agreements with all well owners within the project area, Powertech (USA) will provide an alternate water supply in a quantity equal to the original well if the well has the potential to be impacted by ISR operations or to interfere with ISR operations. Outside of the project area, the potential impacts to existing domestic and stock wells will be low



due to the limited potential drawdown and the large saturated thickness of the Inyan Kara, which exhibits artesian pressure throughout much of the region. Potential impacts north and east of the project area will be further limited by the Dewey Fault and the saturated limits of the Fall River and Chilson.

## 5.0 MONITORING AND MITIGATION PLAN

Potential impacts to domestic and stock wells within the project area will be mitigated in accordance with lease agreements in place with all landowners in the project area. Prior to ISR operations, all domestic wells within the project area and all stock wells within ¼ mile of operating well fields will be removed from private use. Depending on the well condition, location and screen depth, Powertech (USA) may continue to use the well for monitoring or plug and abandon the well in accordance with ARSD 74:02:04:67. Lease agreements for the entire project area currently allow Powertech (USA) to remove and replace water supply wells as needed.

During the design of each well field, all nearby stock wells will be evaluated for the potential to be adversely affected by ISR operations. At a minimum, all stock wells within ¼ mile of each well field will be removed from private use prior to operation of that well field.

As part of the operational monitoring program, Powertech (USA) will monitor all domestic wells within 1.2 miles (2 km) of the project boundary. Domestic wells will be sampled annually for potential water quality impacts as required by the NRC license. During sample collection, static water levels will be measured when access is available. During operation all stock wells within the project area will be monitored quarterly. The operational monitoring program will help ensure that any potential impacts to nearby stock and domestic wells are rapidly detected.

If routine monitoring of stock wells within the project area or domestic wells within 1.2 miles of the project area indicates diminished quantity or quality, Powertech (USA) will notify the well owner in writing and work with the well owner to determine if well replacement is necessary. Replacement wells will be located an appropriate distance from the well fields and may target an aquifer outside of the ore zone. They will provide water in a quantity equal to that of the original well and of a quality which is suitable for the same uses as the original well, subject to the lease agreement (if applicable) and South Dakota water law.

Numerical groundwater modeling results, which conservatively predicted potential drawdown, demonstrate that no nearby water supply wells will be adversely impacted by the proposed Dewey-Burdock Project. Should a nearby well become adversely impacted, Powertech (USA) will work with the affected landowner to develop a site-specific mitigation plan. Potential remediation measures include installation of pumps, lowering of pumps, or well replacement.



## 6.0 PERMIT ADMINISTRATION AND REPORTING

Construction and operation of the Dewey-Burdock Project will be a phased process as described in Section 2.4.2. Current development plans include construction of approximately 600 ISR production wells in the Dewey portion of the project area and 900 ISR production wells in the Burdock portion of the project area. The number and locations of wells are tentative pending delineation drilling that cannot be completed until the NRC license is issued. The number and location of Inyan Kara pumping wells (production wells) will vary throughout the life of the project as well fields are constructed, produced, restored, and decommissioned/reclaimed. Powertech (USA) anticipates that the maximum number of production wells in operation at any one time within the entire project area (including production and restoration) will be 1,000 wells. This is the maximum number of operating production wells requested in this application.

In order to allow DENR to track the location and number of wells diverting water from the Inyan Kara aquifer, Powertech (USA) proposes to submit three reports on a routine schedule as shown in Table 6-1. The planned diversion report will be submitted annually and will describe the number and location of pumping wells to be operated during the next year. The planned diversion report will typically be accompanied by an amendment request to change the number and designated locations of pumping wells. Amendments for changes in diversions would be requested subject to the provisions of SDCL 46-5-13.1, which specifies, “An amendment of an existing permit or license may be granted for a change in use, a change in point of diversion or other change only if the change does not unlawfully impair existing rights and is for a beneficial use and in the public interest.” The amendment requests would demonstrate that “the new or additional point of diversion is from the same source of water [and] no additional water is appropriated” in accordance with SDCL 46-5-13.1.

**Table 6-1: Inyan Kara Water Rights Reporting Schedule**

<b>Report Type</b>	<b>Frequency</b>	<b>Contents</b>
Planned Diversion Report	Annually	Number and location of pumping wells to be operated during the next year.
Operational Report	Annually	Number and location of pumping wells operated during the reporting period. Gross and net Inyan Kara diversion rate (monthly and annual).
Well Completion Reports	Within one month of well completion	As required by SDCL 46-6-11

The operational report will be submitted annually and will describe the number and location of pumping wells operated during the previous year. The well locations for the planned diversion and operational reports will be provided by quarter-quarter section and depicted on a map. The operational report will also provide the monthly and annual gross and net Inyan Kara diversion rates.

Powertech (USA) will also submit well completion reports within one month of completing each production well. Well completion will be defined as the point at which the well screen has been installed and initial well development has occurred. In accordance with SDCL 46-6-11, the well completion reports will be provided on a form supplied by the Chief Engineer.

Powertech (USA) may also submit an amendment application for extension of the construction period as described in Section 2.4.2.



## 7.0 REFERENCES

- Boggs, J.M. and A.M. Jenkins, 1980, Analysis of Aquifer Tests Conducted at the Proposed Burdock Uranium Mine Site, Burdock, South Dakota, Tennessee Valley Authority, Office of Natural Resources, Division of Water Resources, Water System Development Branch, Report No. WR28-1-520-109, May 1980.
- Brobst, D.A., 1961, Geology of the Dewey Quadrangle Wyoming-South Dakota, USGS Bulletin 1063-B.
- Carter, J.M., D.B. Driscoll., J.E. Williamson, and V.A. Lindquist, 2002a, The Black Hills Hydrology Study, U.S. Geological Survey Fact Sheet, FS-046-02.
- Carter, J.M., D.B. Driscoll., J.E. Williamson, and V.A. Lindquist, 2002b, Atlas of Water Resources in the Black Hills Area, South Dakota, U.S. Geological Survey Hydrologic Investigations Atlas, HA 747.
- Darton, N.H., 1909, Geology and Water Resources of the Northern Portion of the Black Hills and Adjoining Regions in South Dakota and Wyoming, USGS Professional Paper 65.
- DENR, 2008, Summary of South Dakota Water Laws and Rules, Prepared by the Water Rights Program, January 2008, available from the Internet as of January 21, 2012: [http://denr.sd.gov/des/wr/wr\\_sum.pdf](http://denr.sd.gov/des/wr/wr_sum.pdf).
- Driscoll, D.G., J.M. Carter, J.E. Williamson, and L.D. Putnam, 2002, Hydrology of the Black Hills Area, U.S. Geological Survey Water-Resources Investigations Report 02-4094, 150 pp.
- Gott, G.B., D.E. Wilcott and C.G. Bowles, 1974, Stratigraphy of the Inyan Kara Group and Localization of Uranium Deposits, Southern Black Hills, South Dakota and Wyoming, USGS Professional Paper 763, prepared on behalf of the U.S. Atomic Energy Commission.
- Kenny, J.F., N.L. Barber, S.S. Hutson, K.S. Linsey, J.K. Lovelace and M.A. Maupin, 2005, Estimated Use of Water in the United States in 2005, USGS Circular 1344, county-level data available on the Internet as of January 21, 2012: <http://water.usgs.gov/watuse/data/2005/>.
- Powertech (USA) Inc., 2009, Dewey-Burdock Project Application for NRC Uranium Recovery License, Fall River and Custer Counties, South Dakota. Technical Report, August 2009.
- Schnabel, R.W. and L.J. Charlesworth, Jr., 1963, Geology of the Burdock Quadrangle, South Dakota, USGS Survey Bulletin 1063-F, Plate 17.